

# Recurrent Neuronal Models

*Vicky R. Zhu*

*Advisor: Dr. Robert Rosenbaum*

Mar. 19th, 2020



# A Brain-Mind Odyssey:

- A **brain** is a complex organ controls over a body.
- Each region codes specific features of an environment. All together form our experience of the world.
- A brain has billions of neurons.
- **Neurons** are specialized cells in the nervous system that transmit information to other nerve cells through excitation.

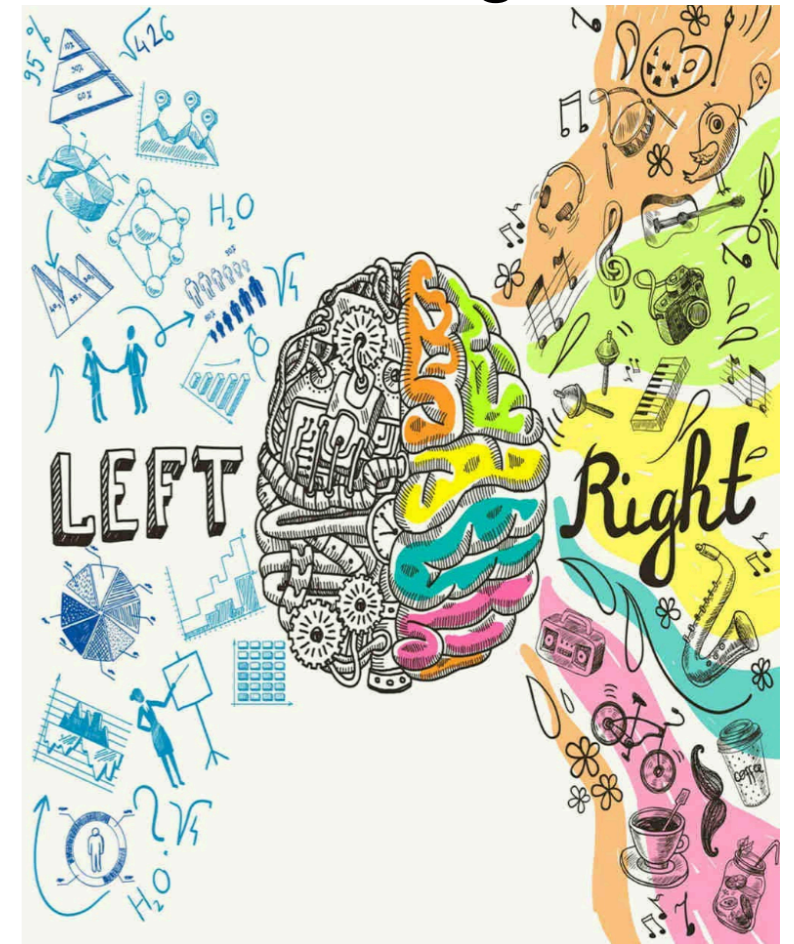

**dendrite**

**soma**

**axon**

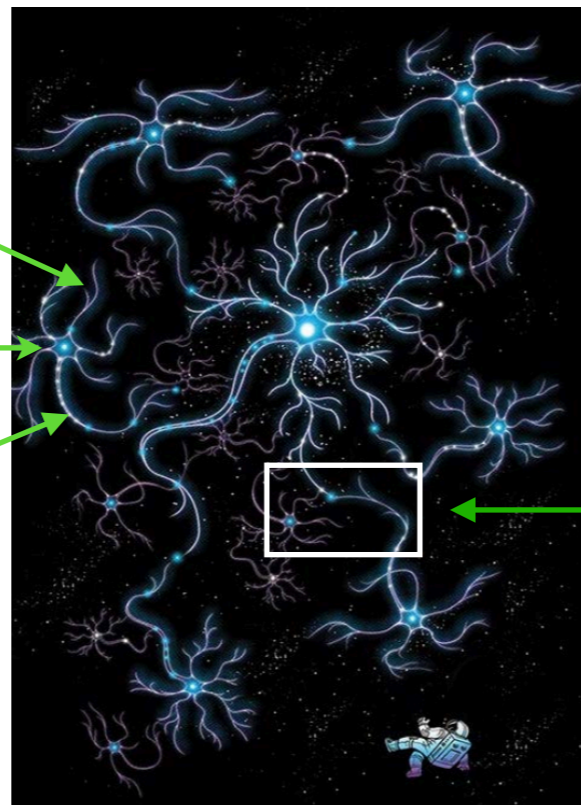

**Synapse** is the connection between two neurons.

# A Brain-Mind Odyssey:

- A neuron has a **membrane** that is made of a bilayer of lipid molecules with many types of protein embedded in it.

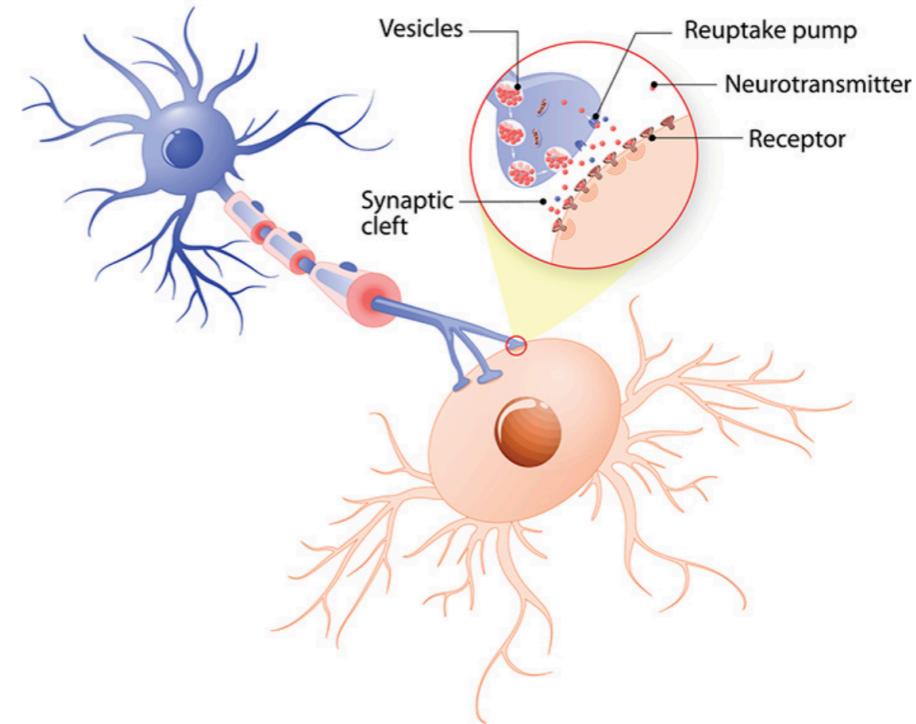
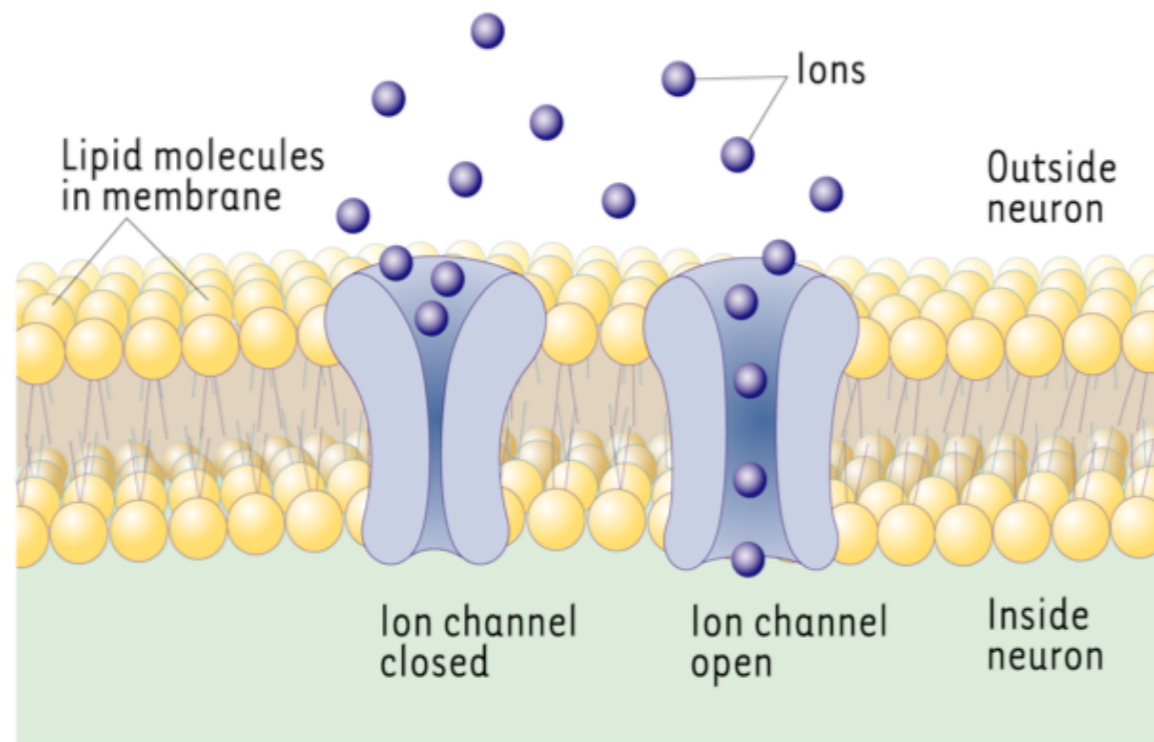

- Neurons send and receive signals via **neurotransmitters**, a type of chemical messenger controls the ion channels to change the neuron's membrane potential (voltage differential).
- When a neuron has large voltage differential (depolarized), an action potential/**spike** happens.

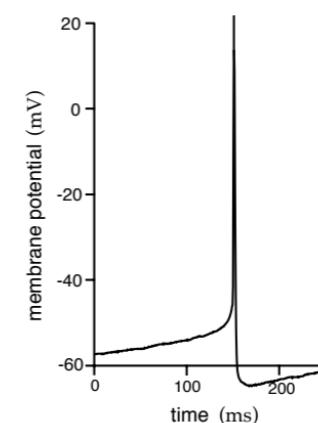

# Hodgkin-Huxley Model

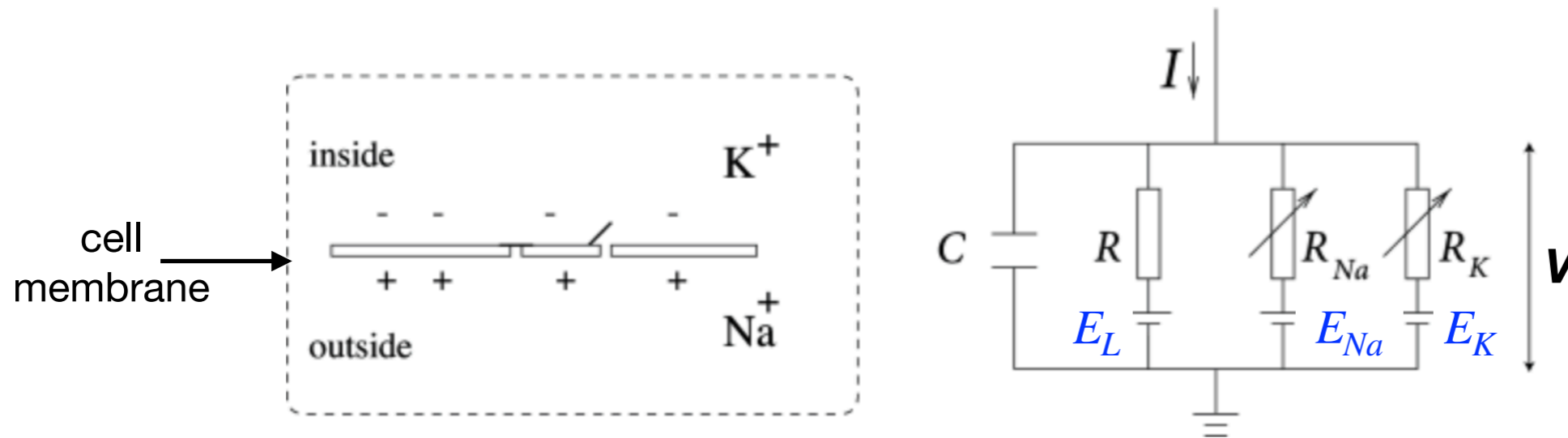

C: capacitance, measures its lipid bilayer allowance for the voltage differential.

R: resistor, measures the allowance for the ions to pass through.

$E$ , reverse potentials: a measure of zero net flow.

- **A biological model:** want to measure current(I) across the cell membrane(C) through the changes of membrane potentials(V),  $I_c = C \frac{dV}{dt}$
- By **conservation** of electric charge,  $I_{inj.} = I_C + I_{pass}$   
The charging current  $I_C = C \frac{dV}{dt} = -I_{pass} + I_{inj.}$
- Apply **Ohm's law**,  $I_{pass} = gV$ , so  $I_{total} = \sum_{ion} g_{ion}(V - E_{ion})$   
—g: conductance: measures the resistant level of each ion channel.

# Hodgkin-Huxley Model

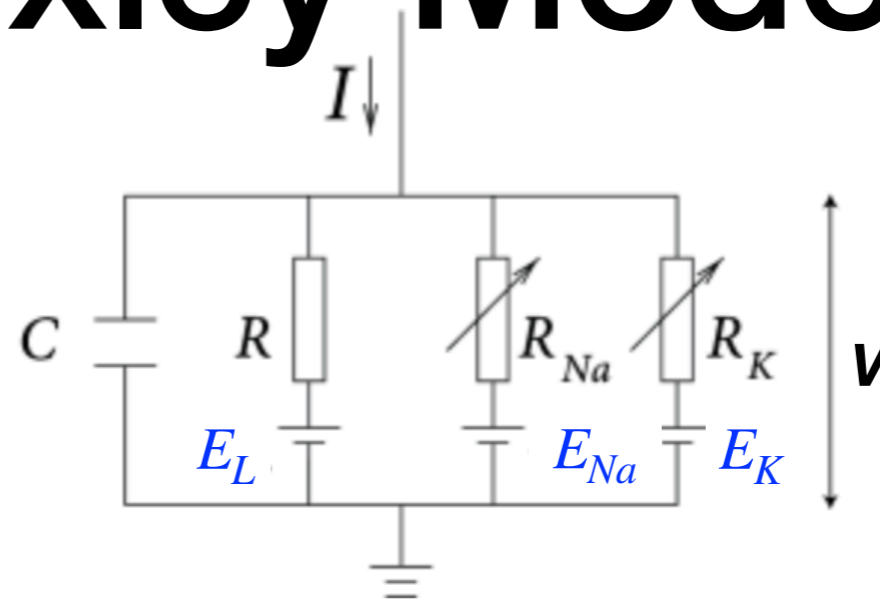
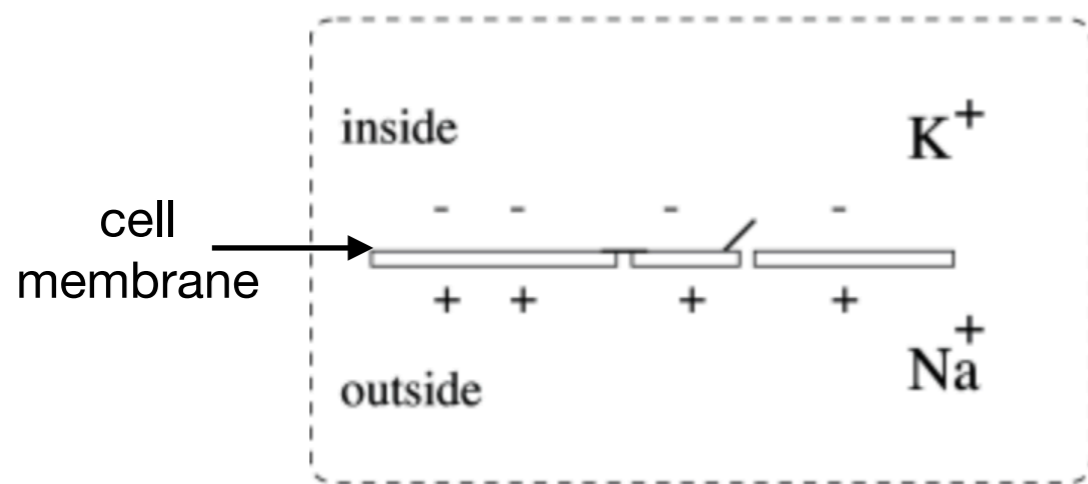

$$I = C \frac{dV}{dt} = -\bar{g}_L(V - E_L) - \bar{g}_K n^4 (V - E_K) - \bar{g}_{Na} m^3 h (V - E_{Na}) + I_{inj}.$$

$$\frac{dn}{dt} = (1 - n)\alpha_n(V) - n\beta_n(V)$$

$$\frac{dm}{dt} = (1 - m)\alpha_m(V) - m\beta_m(V)$$

$$\frac{dh}{dt} = (1 - h)\alpha_h(V) - h\beta_h(V)$$

**Na: 2 types of gates**  
**m is fast, h is slow**

gating variables(n, m, h): probability controls ion channels.

(i.e. the effective conductance of Na is modelled as  $\frac{1}{R_{Na}} = g_{Na} m^3 h$ )

— $\alpha$ : the rate of closed gates open;  $\beta$ : the rate of open gates close

# Hodgkin-Huxley Model

HH model describes the **spiking** dynamics:

- Spike(voltage difference=100mV) appears when given strong input;
- Spike is short(width=2.5ms);
- After spike,  $V$  falls below resting potential,  $V_{re} = -65mV$ .

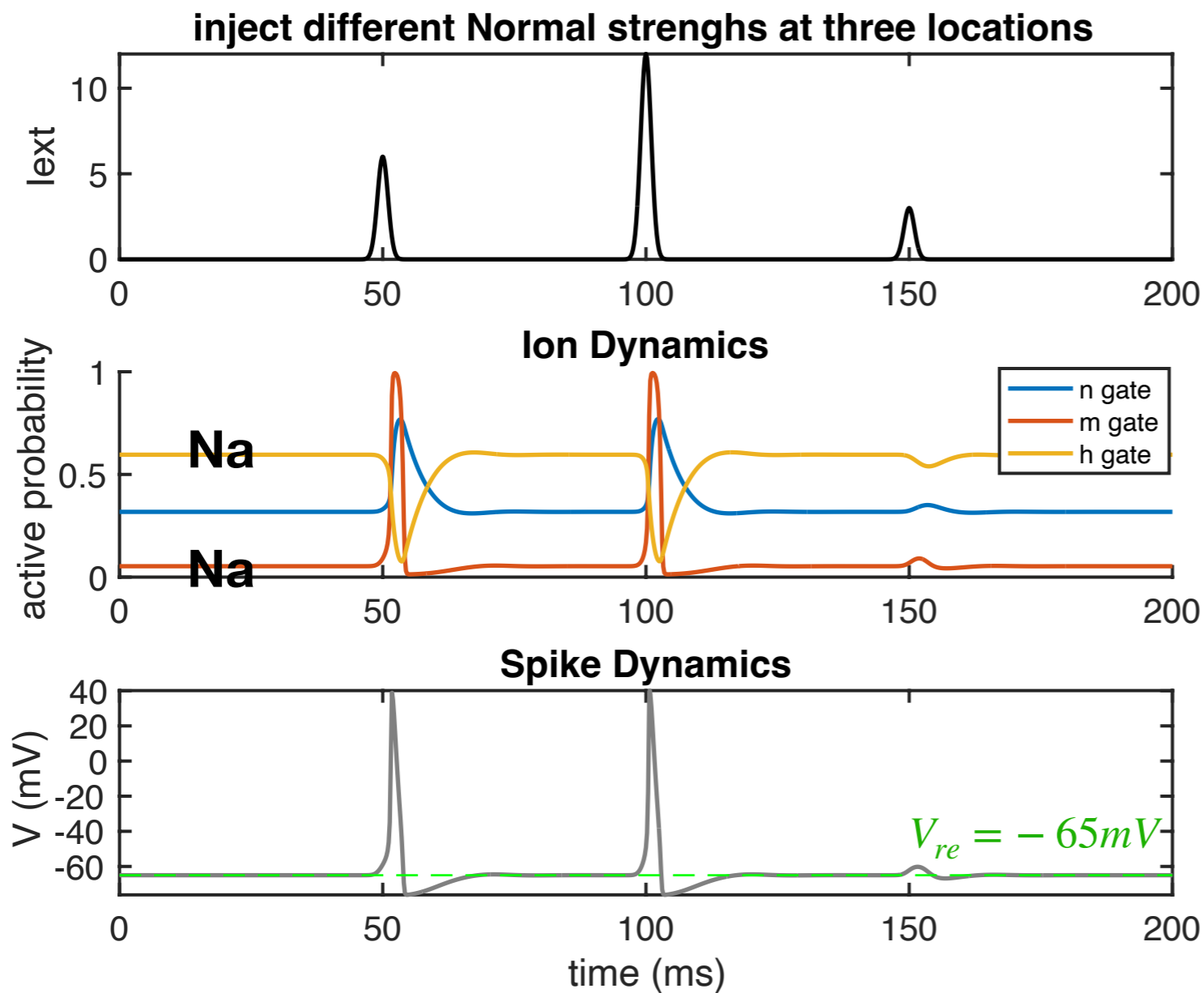

Ion dynamics:

- m causes  $V$  to increase,
- h stops  $V$  from increasing,
- n causes  $V$  to decrease

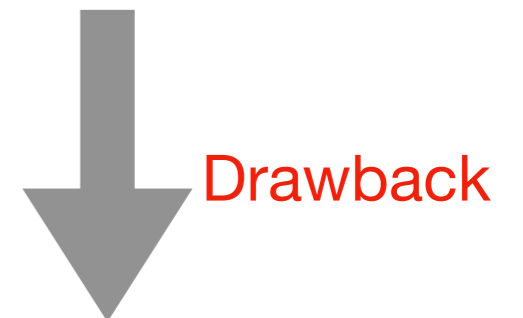

**computational complex**

# Integrate-and-fire Models

**Leaky IF model :**  $C \frac{dV}{dt} = -g_L(V(t) - E_L) + I(t)$

when  $V(t) > V_{th} \approx 10mV$ : record a spike,

reset  $V(t)$  to  $V_{re} \approx -75mV$

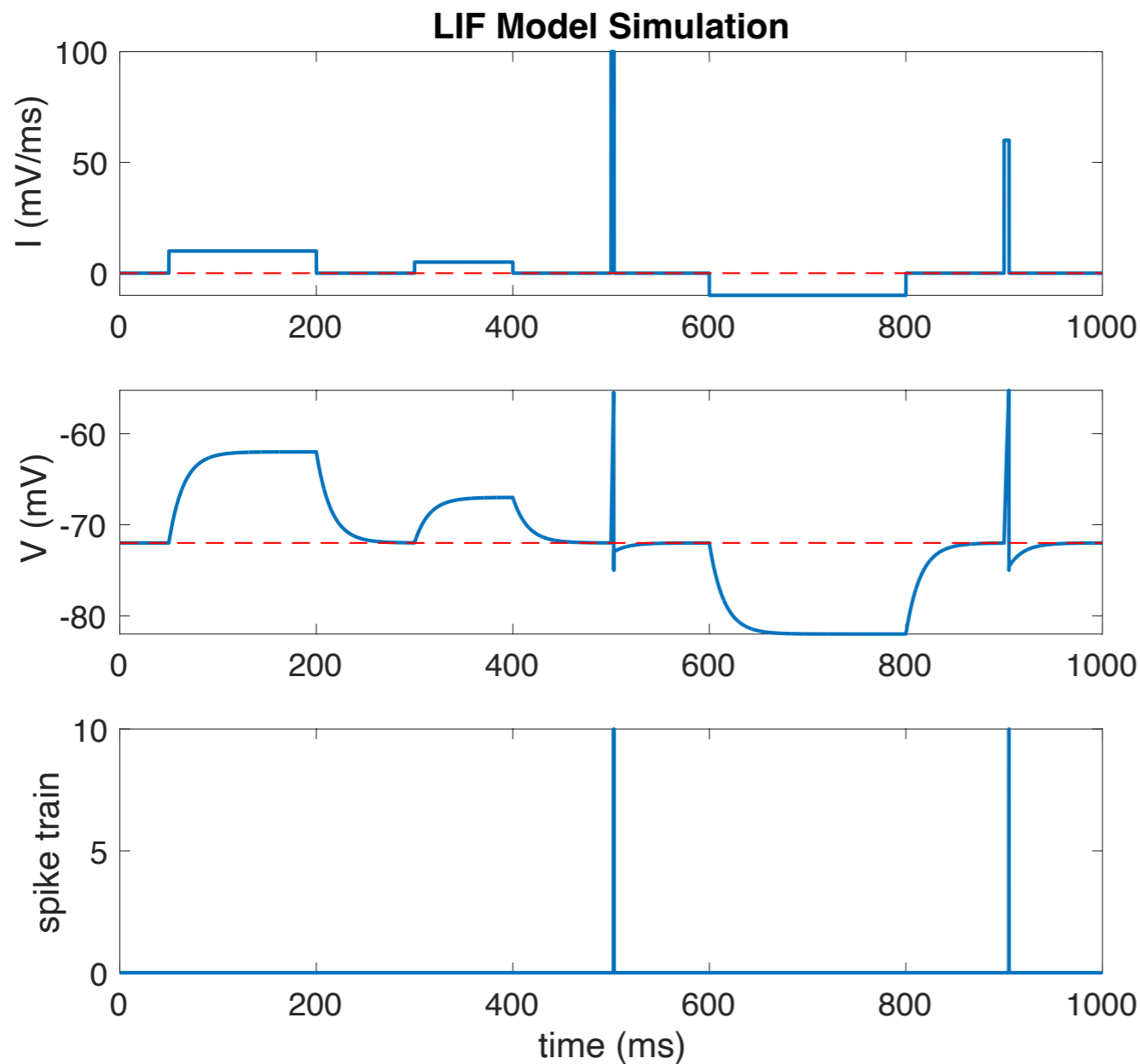

- Reset is to capture K channel effect. (*i.e.* spikes have the same height)
- This model captures neurons decay back to the  $E_L$  w/o input. (*i.e.* solve the ode, exponential decay)



**Drawback**

Na channels are ignored  
(less realistic!)

# Integrate-and-fire Models

**Exponential IF model:**  $C \frac{dV}{dt} = -g_L(V(t) - E_L) + g_L \Delta_T \exp\left(\frac{V(t) - V_T}{\Delta_T}\right) + I(t)$

$V_T \approx -55mV$ , is a **soft threshold**,  $\Delta_T$  is a scaling factor.

when  $V(t) > V_{th}$ : record a spike, reset  $V(t)$  to  $V_{re}$

**EIF Model Simulation with constant input**

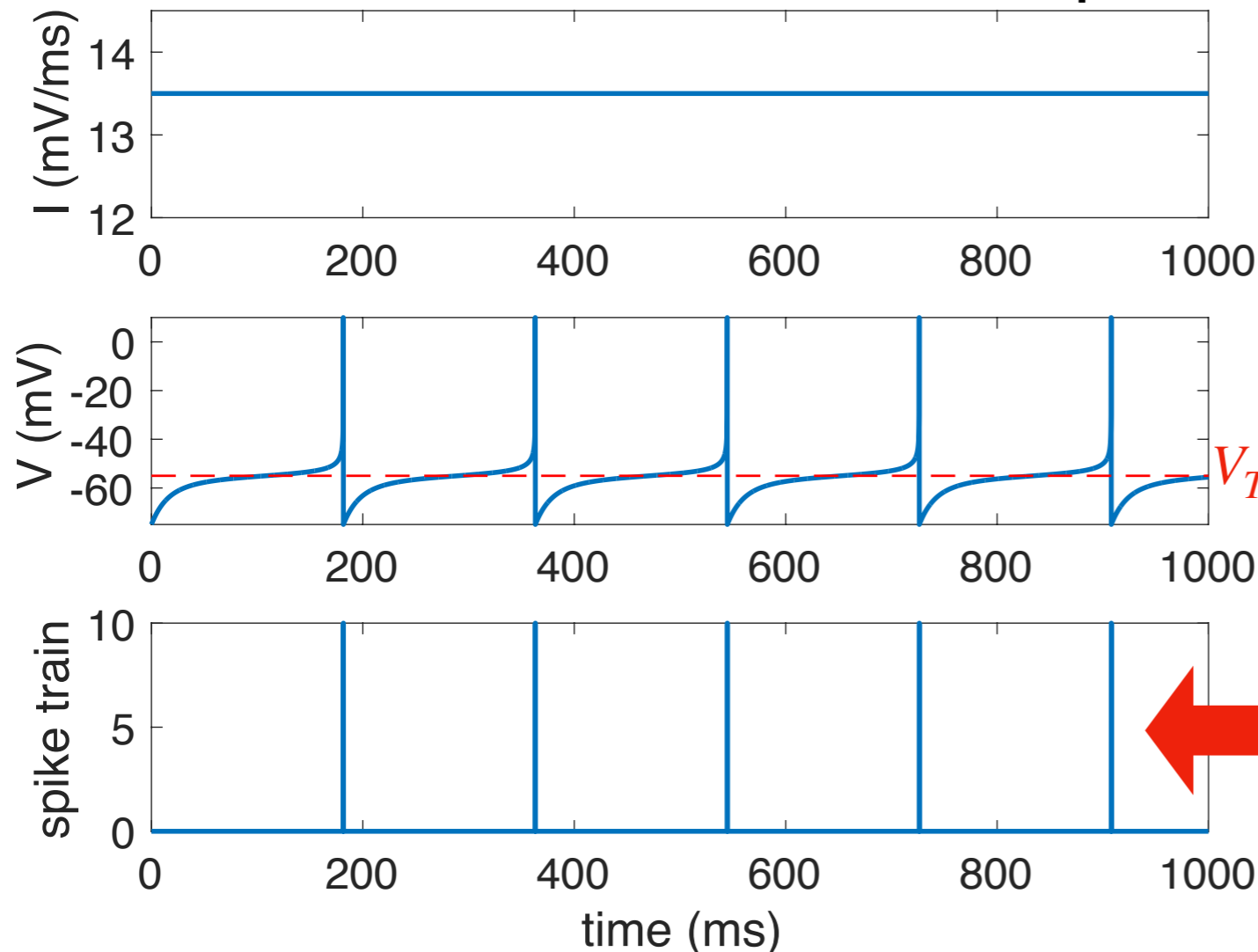

- The exp. term approximates the effects of Na channel in HH model.
- When  $\Delta_T \rightarrow 0$ , EIF = LIF

**Spike train:** a point process,

$$S(t) = \sum_n \delta(t - t_i), \text{ can be modelled as } Pois(r)$$

**Spike rate:**  $r(t) = \lim_{\Delta \rightarrow 0} \frac{\int_t^{t+\Delta} S(t) dt}{\Delta} = E[S(t)]$



# Synapses on IF models

So far, neuron models driven by an applied current,  $C \frac{dV}{dt} = f(V, I) + I_{app}(t)$

other neurons

**Synaptic current** : in post-syn neurons' membrane,  $I_{syn}(t) = g_{syn}(t) \cdot (V(t) - E_{syn})$   
 after pre-syn neuron spikes, the **conductance**:  $g_{syn}(t) = J \cdot \sum_n \alpha(t - t_{spike})$

**Synaptic strength**: J with  $J_e > 0$  and  $J_i < 0$

**Q: What does a post-syn neuron look like after a pre-syn neuron spikes?**

neurotransmitter: smooth out synaptic activities,  $\alpha(t) = \frac{1}{\tau_{syn}} \exp\left(-\frac{t}{\tau_{syn}}\right) H(t)$

**Post-synaptic conductance waveform,  $\alpha(t)$**

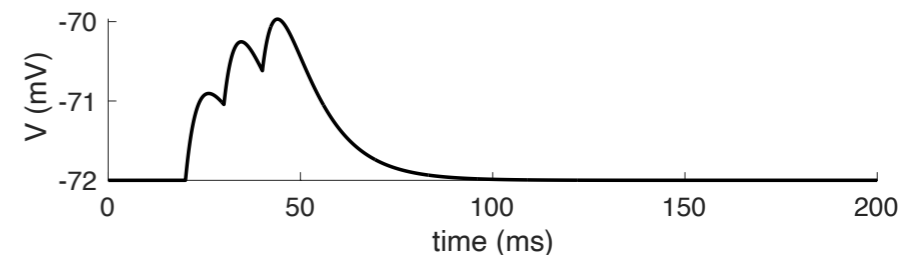
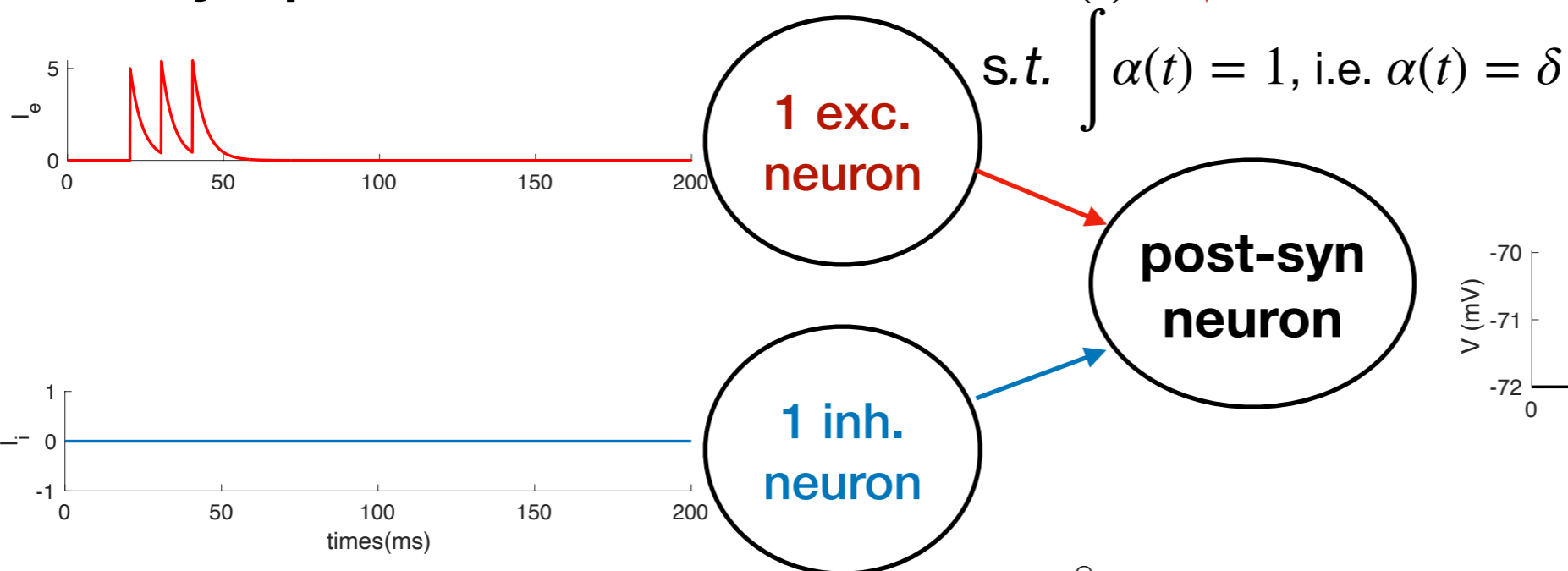

# Synapses on IF models

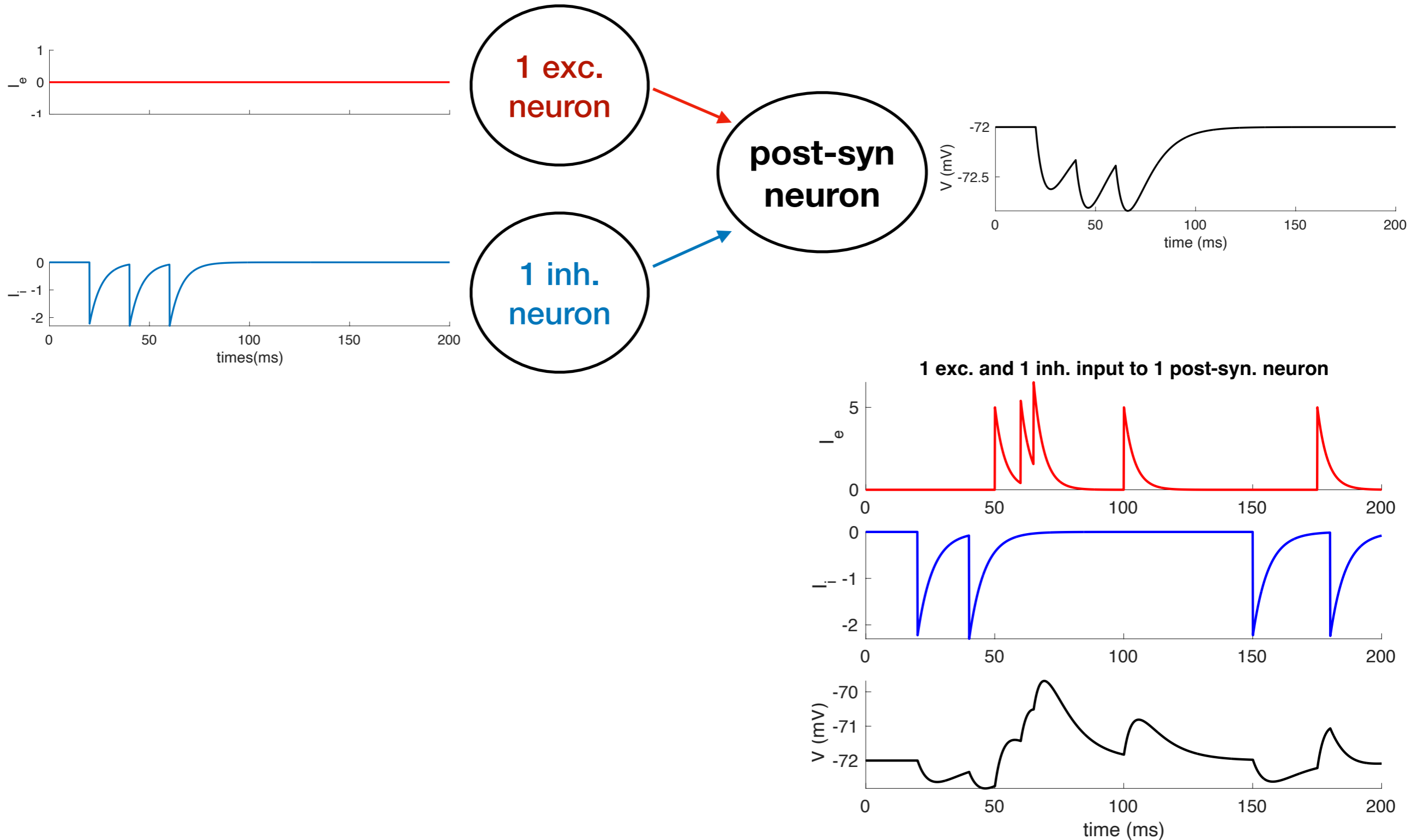

# Feedforward Input

More realistic, a post-syn neuron  $j$  receives inputs from many presynaptic neurons.

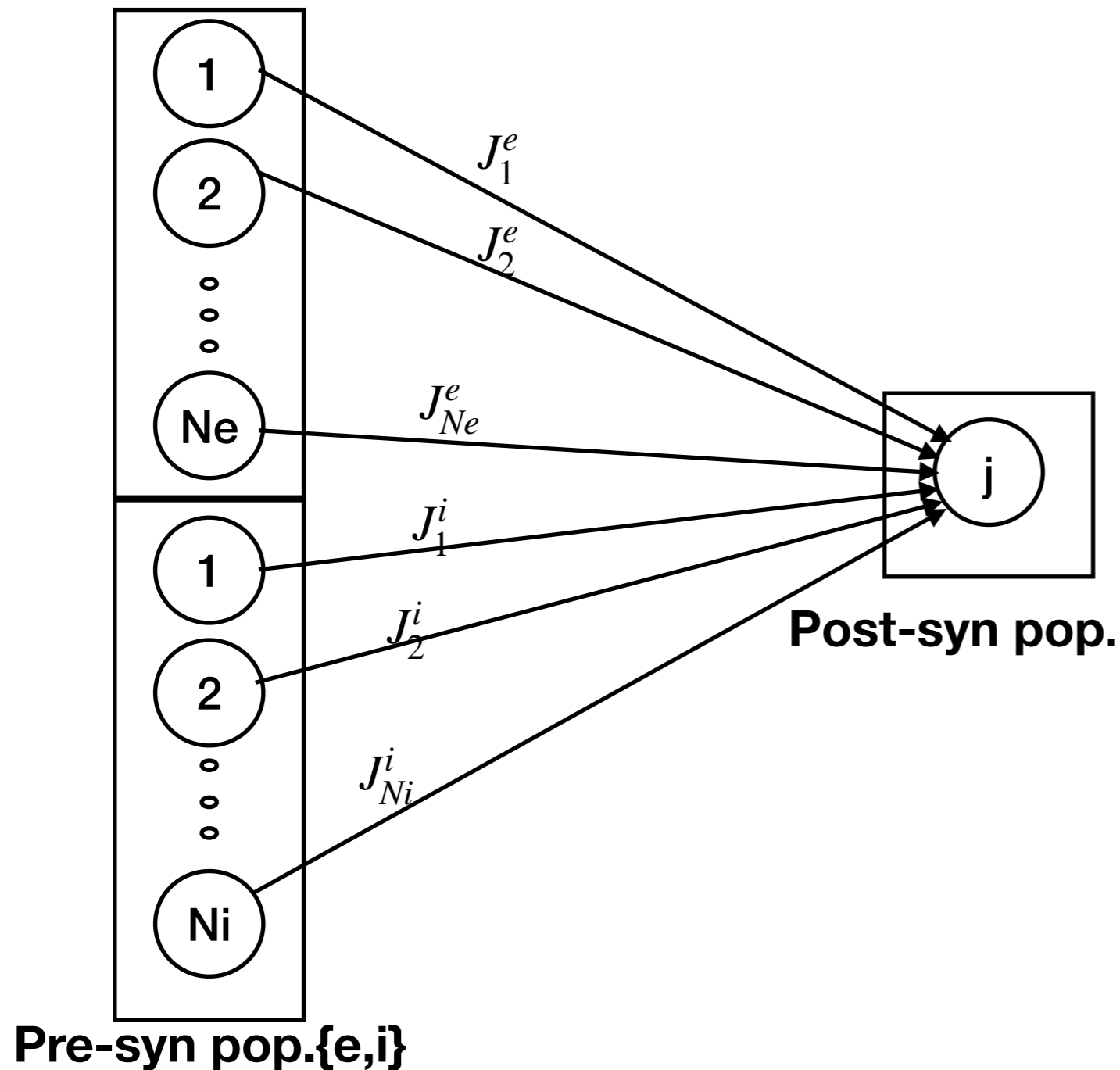

Solve the ode for  $\bar{I}_{syn}$

# Mean-field Input

$$\begin{cases} \tau \frac{dV_j}{dt} = f(V_j) + I_{syn} \\ \tau_b \frac{dI_b}{dt} = -I_b + J^b S^b \end{cases} \quad \text{with } b = \{e, i\}; \text{ and } S^b(t) \sim \text{Pois}(r^b), \text{ so } E[S^b] = r^b$$

- Take expectation(time-average):  $\tau_b \frac{d\bar{I}_b}{dt} = -\bar{I}_b + J^b E[S^b]$
- Solve for the ODE:  $\bar{I}_b$  converges exponentially to the fixed point,  $J^b r^b = \sum_k^{N_b} j_k^b r^b$ .
- **Mean-field Input:**  $\bar{I}_b = N_b j^b r^b$  is the time-average of  $I_b(t)$ .
- Without  $I_{app}(t)$ , Mean Total input,  $\bar{I} = \bar{I}_e + \bar{I}_i$

Mean-field Synaptic Current Inputs

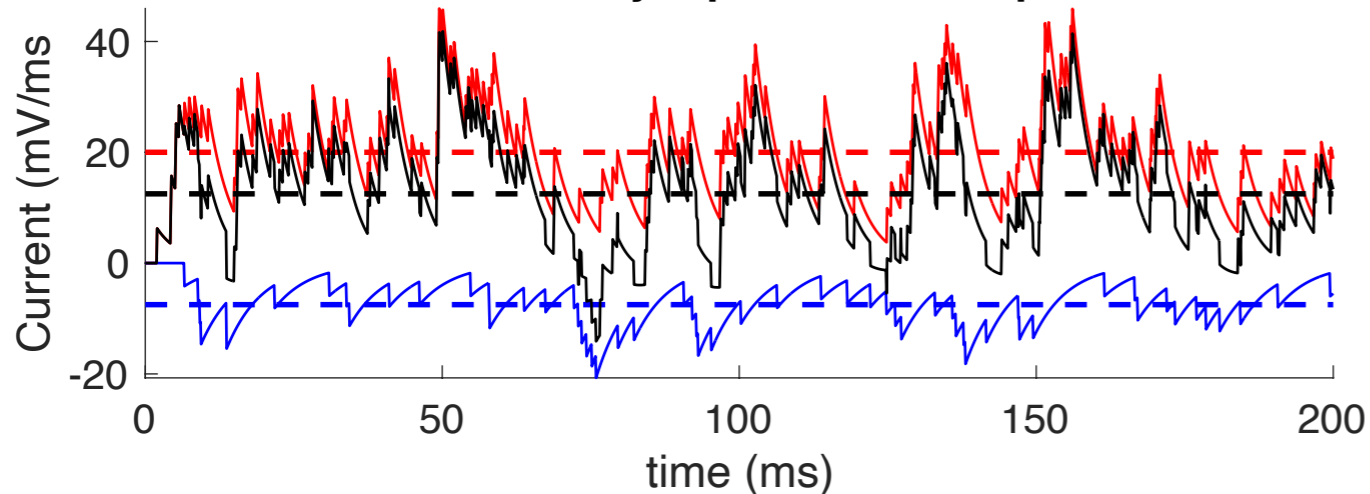

Membrane Potential Dynamics for Post-syn. Neuron j

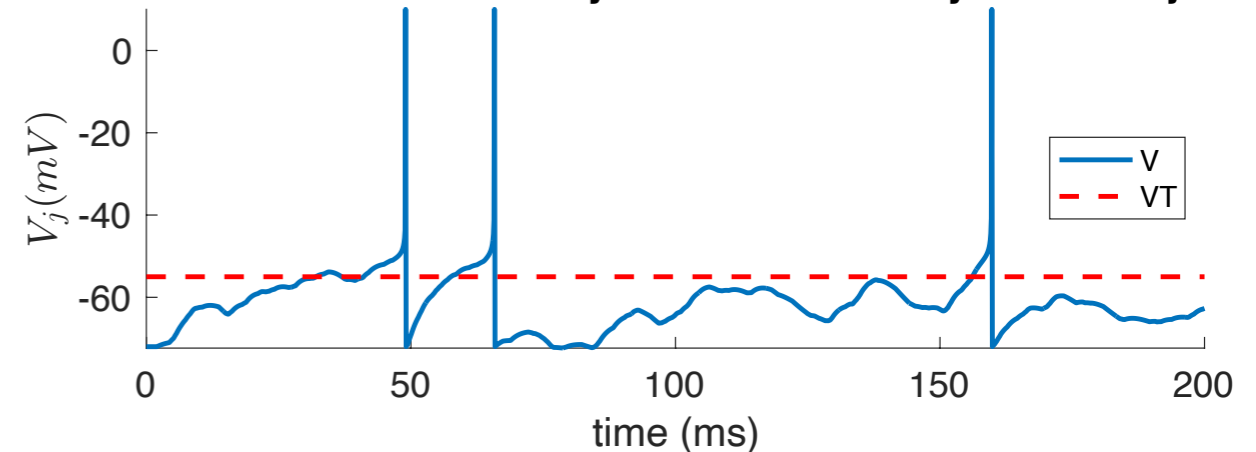

# Feedforward Network Models

More realistic: we have a post-syn neuron population instead of a single neuron.

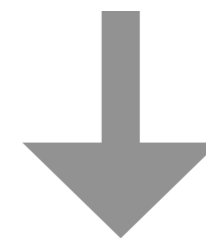
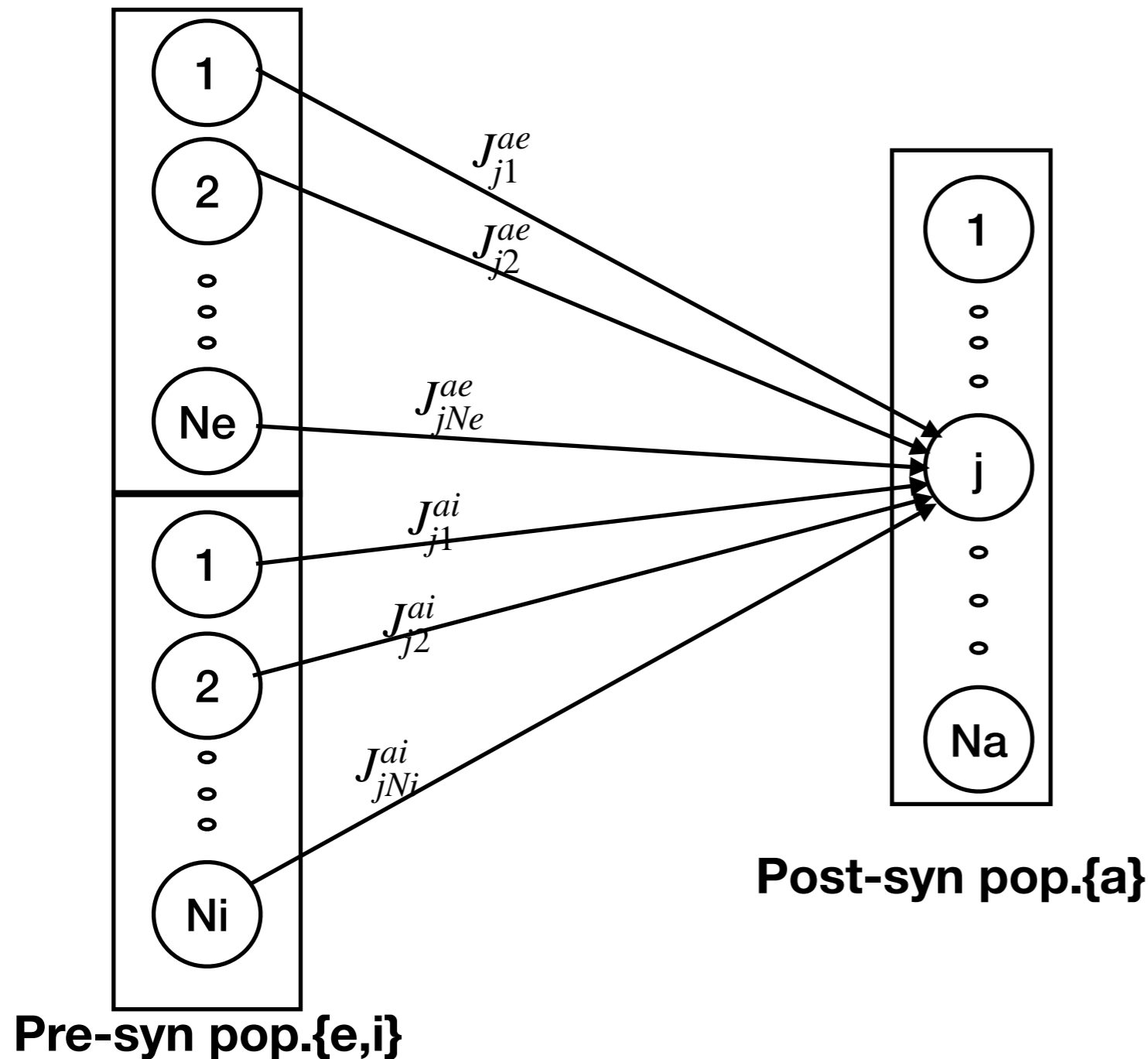

Solve the ode for  $\bar{I}_{syn}$

From mean-field theory: 
$$\bar{I}_{syn} = \frac{1}{N_a} \sum_j^{N_a} (N_e p_{ae} J_{ae} r_e + N_i p_{ai} J_{ai} r_e)$$

# Feedforward Network Models

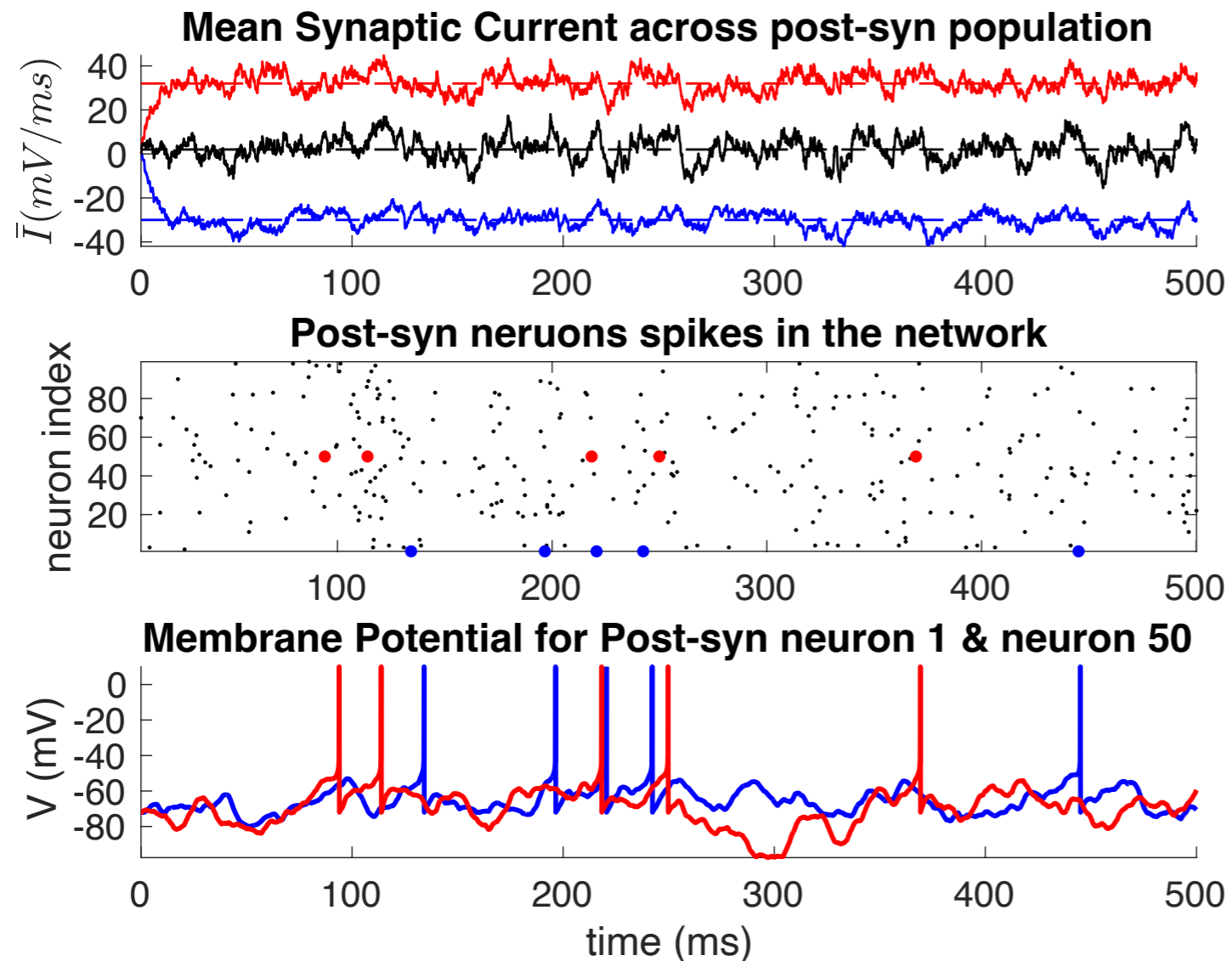

- fluctuation around mean;
- Individual neuron receives large exc. & inh. input;
- cancellation,  $\bar{I}_{total}$  is small.

Balanced Network?

Firing rate,  $r^{post}$  ?

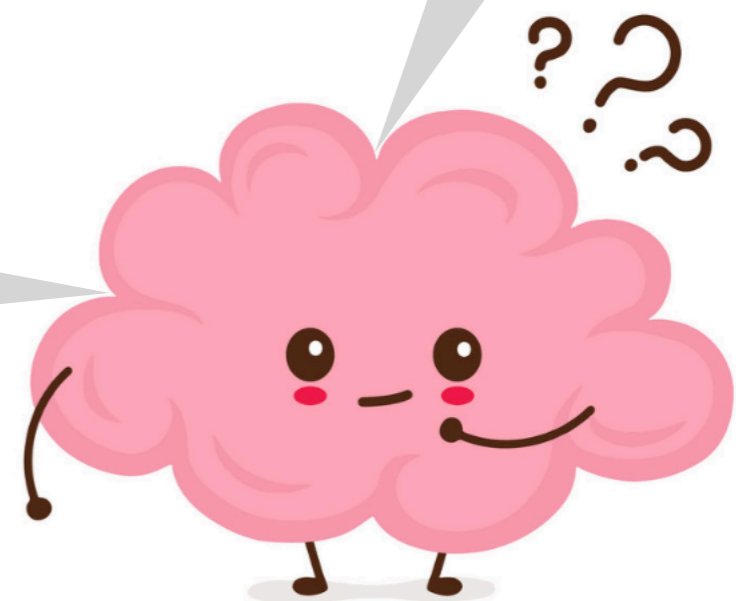

# Claim: $\bar{r}^{post} \approx f(\bar{I})$

**Dales Law:** a neuron connects to all its post-syn targets with the same “type” of synapse.

Recall, 
$$\bar{I}_{syn} = \frac{1}{N_a} \sum_j^{N_a} (N_e p_e j_e r_e + N_i p_i j_i r_i)$$

If defined a weighted connectivity  $W = \begin{bmatrix} w_{ee} & w_{ei} \\ w_{ie} & w_{ii} \end{bmatrix} = \begin{bmatrix} + & - \\ + & - \end{bmatrix}$  s.t.  $w_{ab} = N_b p_{ab} j_{ab}$

In matrix notation,  $\bar{I} = W r^{pre}$ ; with  $r^{pre} = \begin{bmatrix} r_e \\ r_i \end{bmatrix}$

Approximation of r

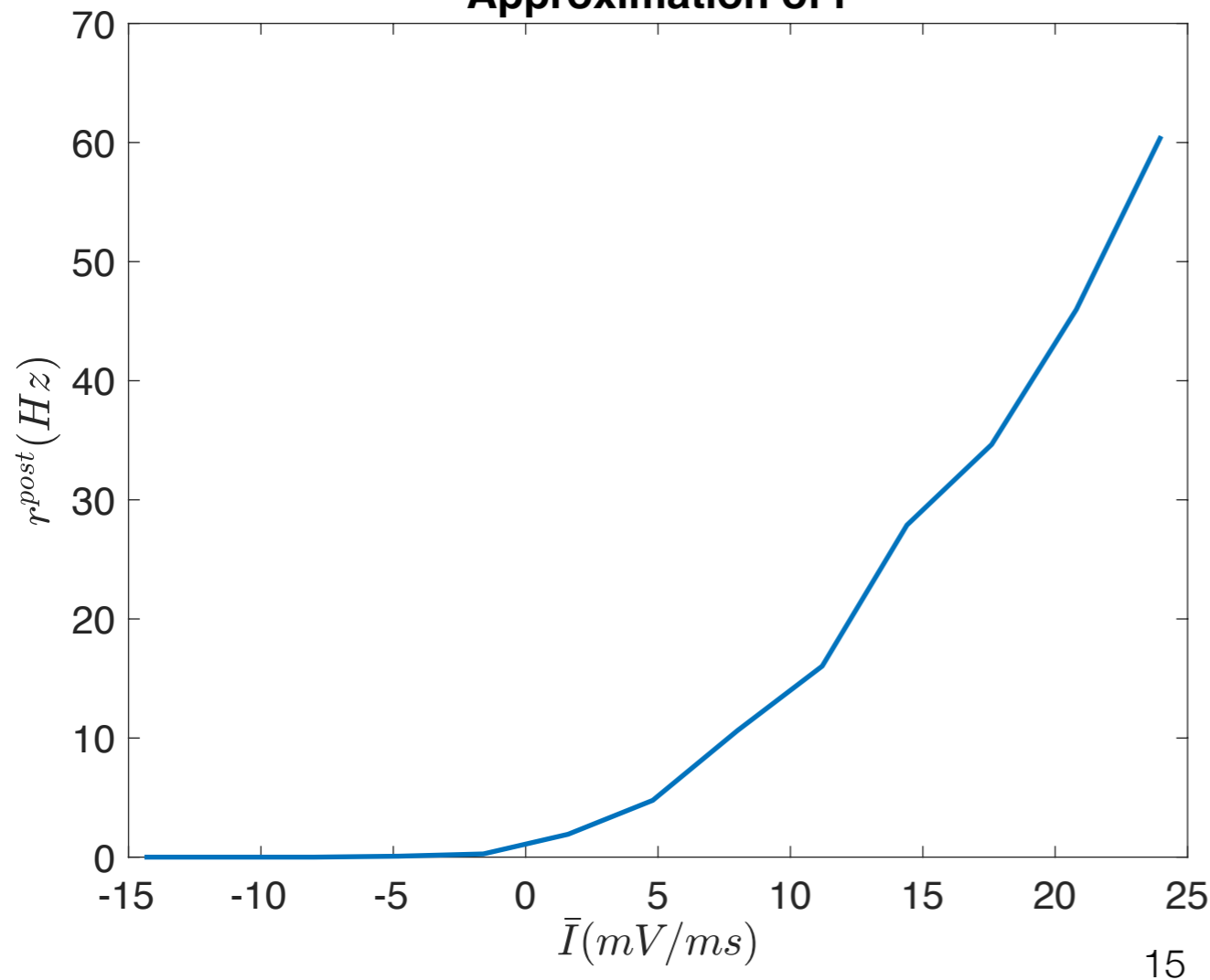

- approximate  $\bar{r}^{post} \approx f(W r^{pre})$
- $f(\cdot)$  is non-decreasing  
(i.e.  $f(\cdot) = [\cdot]^+$ ,  $f(\cdot) = \text{sigmoid} \dots$ )

# Rate Models

So far, we discussed spiking models that track the membrane potential,  $V$

**Rate Model** : focus on the frequency of spikes in large network

f-I curve comparison from Spiking & Rate Models

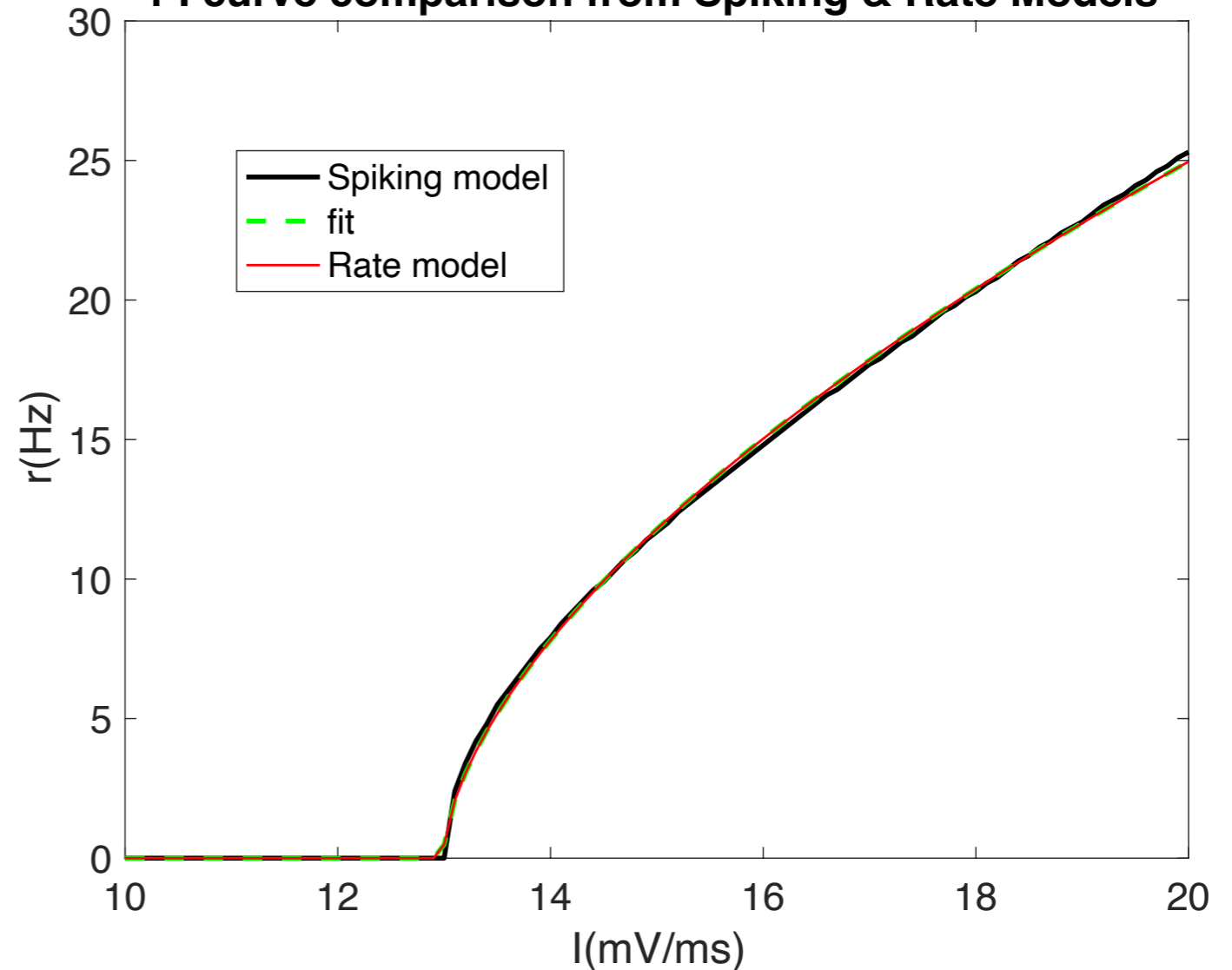

$$\tau_r \frac{d\vec{r}}{dt} = -\vec{r} + f(W\vec{r} + X)$$

Drawback

**This is one neuron spiking rate and it ignores biophysical details!!!**



# Feedforward Network Models

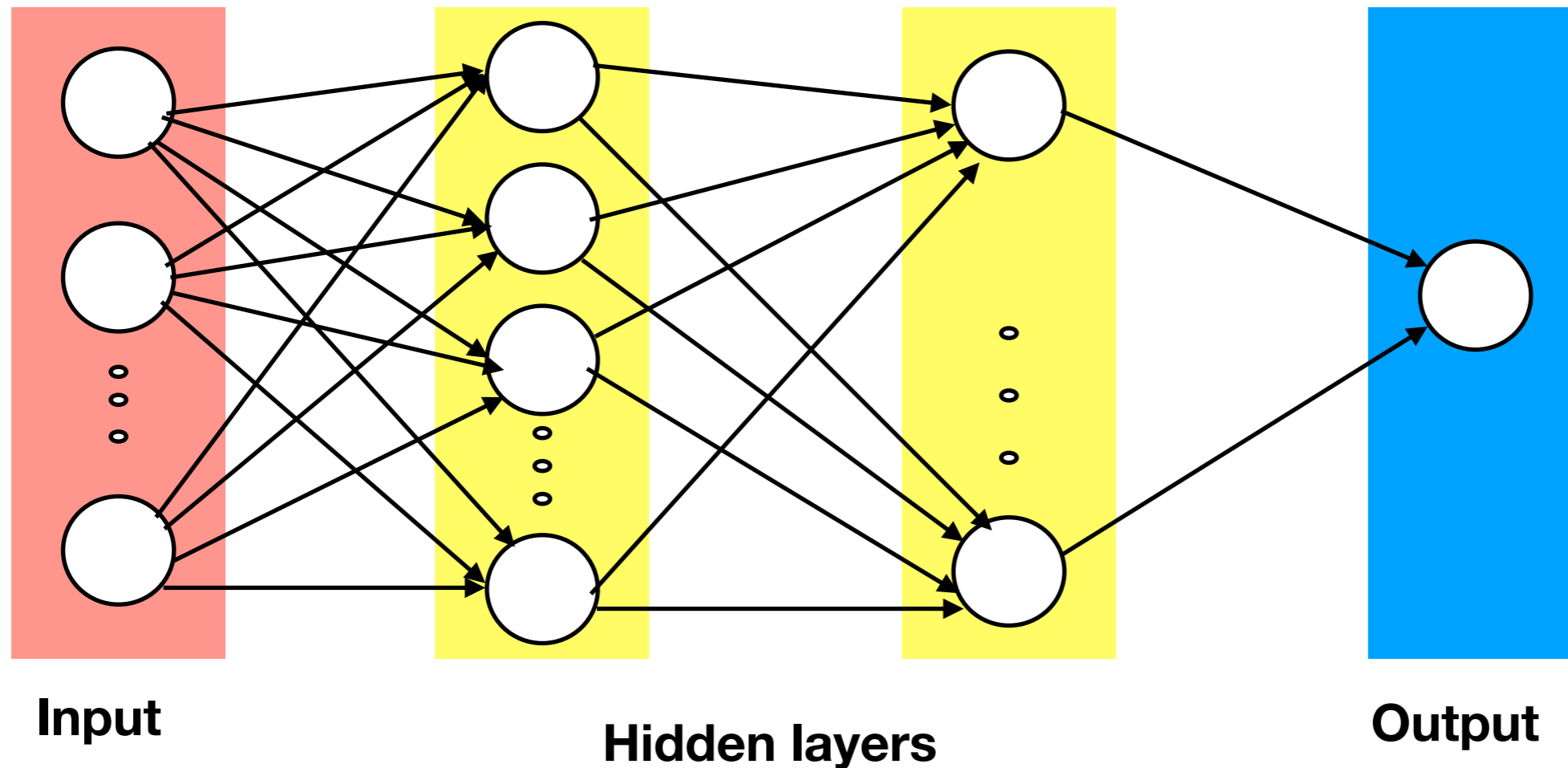

**One advantage of rate model is to connect with Artificial Neural Networks**

$$\begin{cases} r^1 = f(W^1 r^0) \\ r^2 = f(W^2 r^1) \\ \dots \\ r^m = f(W^m r^{m-1}) \end{cases}$$

# Recurrent Network Models

- Reality: Neurons in the same layer are interconnected
- Recurrent Network: there is a path from a neuron back to itself.

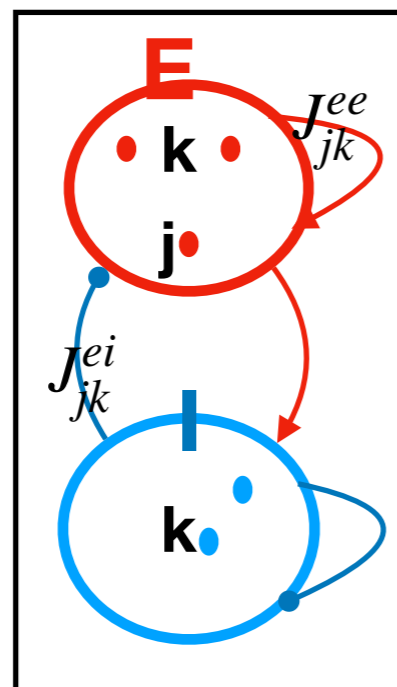

**Recurrent Network**  
(i.e. Cortex)

$$\left\{ \begin{array}{l} \tau \frac{d\vec{V}_e}{dt} = f(\vec{V}_e) + \vec{I}_{ee}(t) + \vec{I}_{ei}(t) + \vec{I}_{app,e}(t) \\ \tau_e \frac{d\vec{I}_{ee}}{dt} = \vec{I}_{ee} + J_{ee} \vec{S}_e(t) \\ \tau_e \frac{d\vec{I}_{ei}}{dt} = \vec{I}_{ei} + J_{ei} \vec{S}_e(t) \\ \tau \frac{d\vec{V}_i}{dt} = f(\vec{V}_i) + \vec{I}_{ie}(t) + \vec{I}_{ii}(t) + \vec{I}_{app,i}(t) \\ \tau_i \frac{d\vec{I}_{ii}}{dt} = \vec{I}_{ii} + J_{ii} \vec{S}_i(t) \\ \tau_i \frac{d\vec{I}_{ie}}{dt} = \vec{I}_{ie} + J_{ie} \vec{S}_i(t) \end{array} \right.$$

# Recurrent Network Models

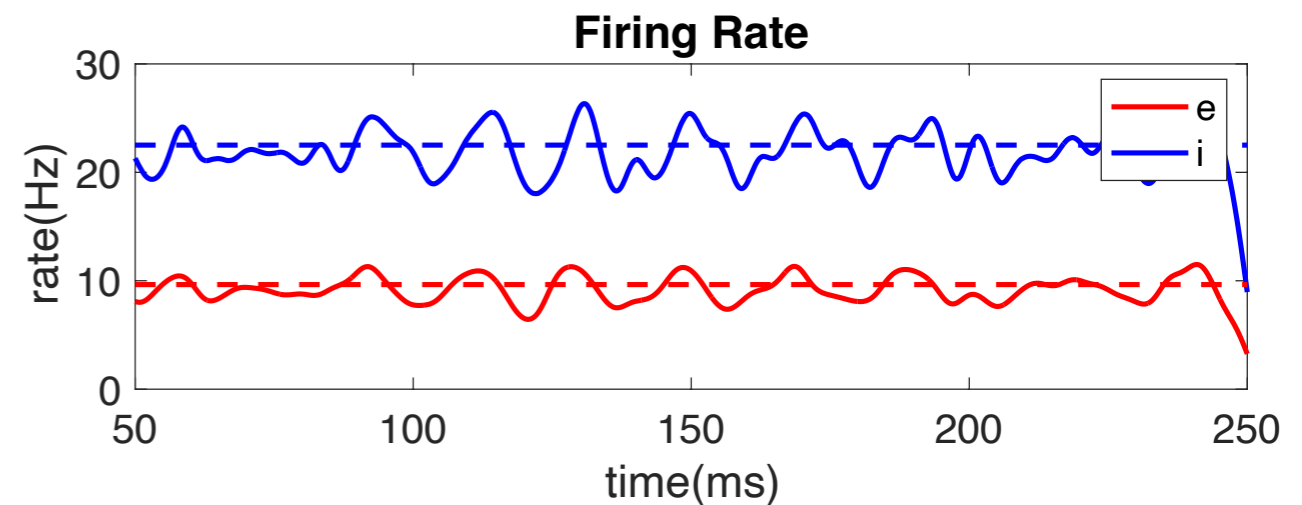
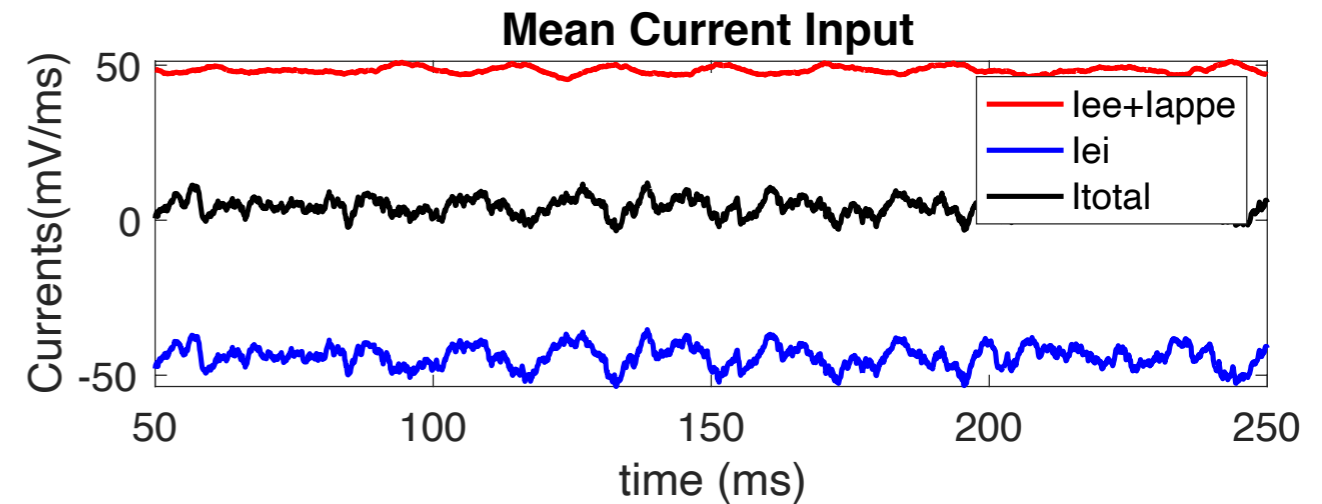
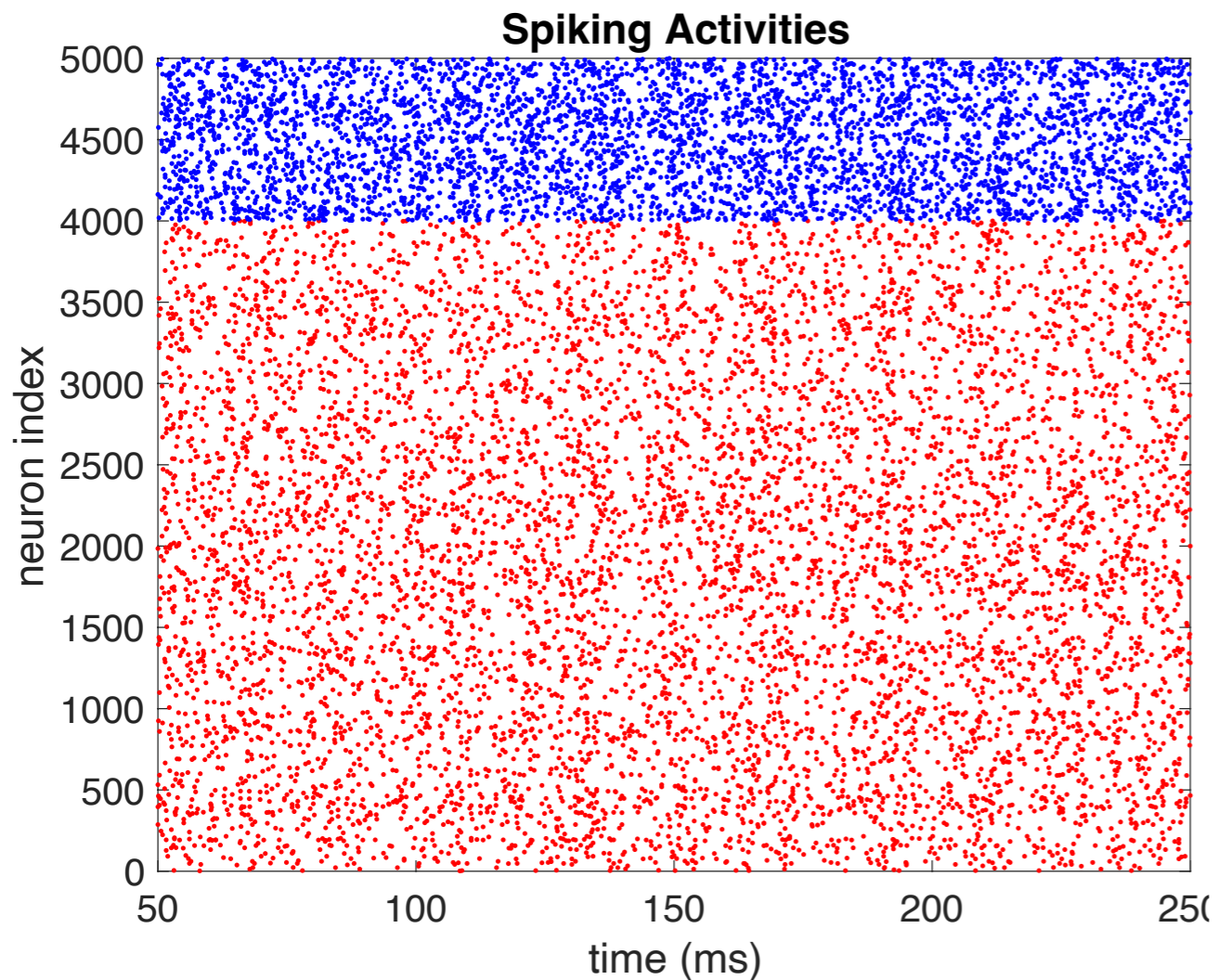

- Irregular, asynchronous

- Inh. rate  $>$  exc. rate

**So far our models are with fixed N, what if N gets large?**

# Balanced Network Models

“Mean total input stays  $\bar{I} \sim O(1)$  via cancellation”

Assumption on the network:  $p_{ab}$  and the connectivity strength  $j_{ab} \sim O(1)$ ;

$$\text{So } J^{ab} = \frac{1}{\sqrt{N}} \begin{cases} j_{ab} & \text{with } p_{ab} \\ 0 & \end{cases} \sim O\left(\frac{1}{\sqrt{N}}\right)$$

1. This implies weighted connectivity matrix,  $W = \begin{bmatrix} w_{ee} & w_{ei} \\ w_{ie} & w_{ii} \end{bmatrix} = \begin{bmatrix} + & - \\ + & - \end{bmatrix}$

with  $w_{ab} = j_{ab} p_{ab} q_b \sim O(1)$ , where  $q_b = \frac{N_b}{N}$

2. Input current,  $I_j^a(t) = \sum_{b=e,i,x} \left[ \sum_{k=1}^{N_b} J_{jk}^{ab} (\alpha_b * S_k^b)(t) \right] = \sum_{b=e,i,x} \left[ \sum_{k=1}^{N_b} \frac{j_{ab}}{\sqrt{N}} (\alpha_b * S_k^b(t)) \right]$

3. After taking time-average,  $\bar{I} = \sqrt{N} [w_{ae} r_e + w_{ai} r_i + w_{ax} r_x]$   
 $= \sqrt{N} [Wr + X]$

4. In the balanced context,  $\bar{I} \sim O(1)$  implies that  $[Wr + X] \sim O\left(\frac{1}{\sqrt{N}}\right)$  from cancellation.

Taking the limit as  $N \rightarrow \infty$ , solve for  $r$  :  $r \approx -W^{-1}X \sim O(1)$

# Balanced Network Models

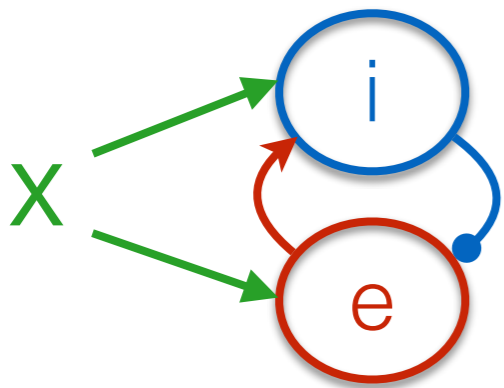

$$\mathbf{r} \approx -W^{-1}\mathbf{X}$$

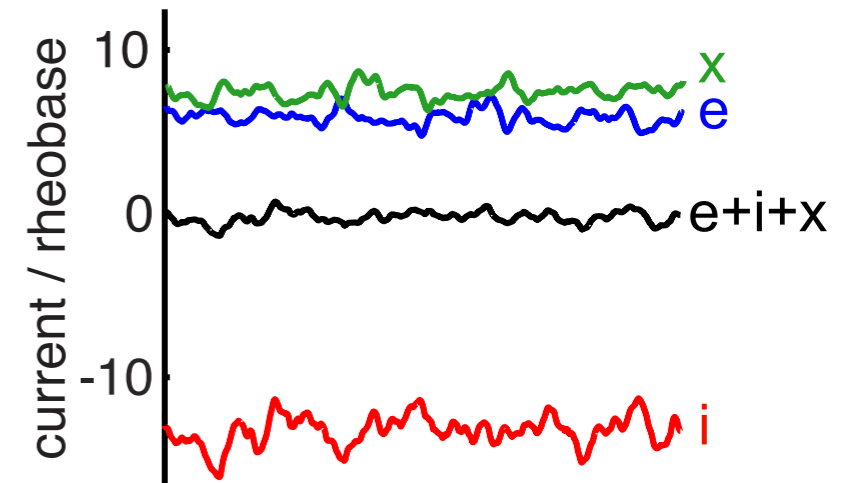

- Approximate E-I balance is widely observed in cortex

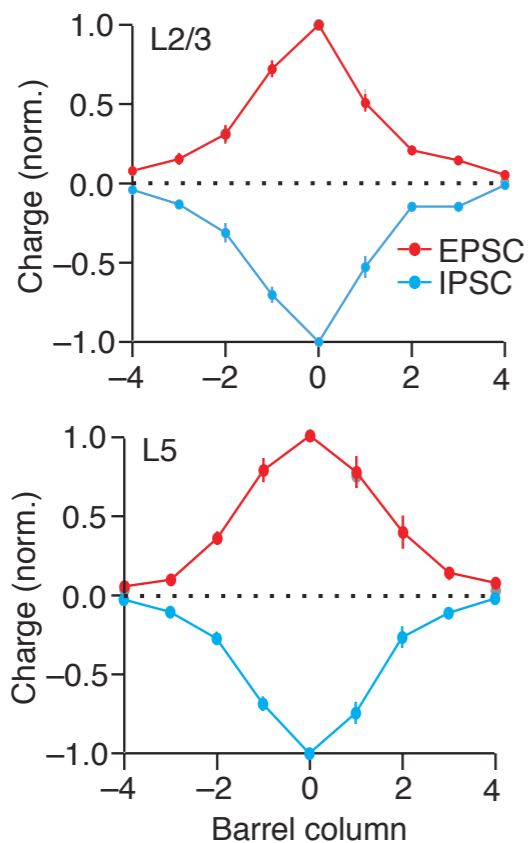

(Adesnik and Scanziani, *Nature*, 2010)

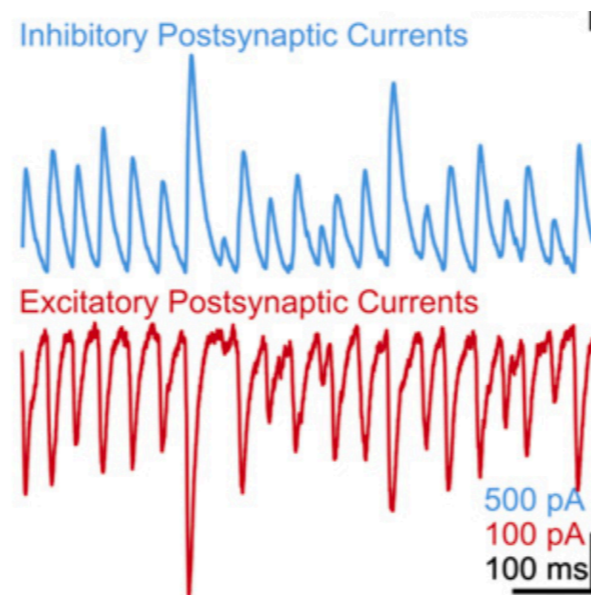

(Atallah and Scanziani, *Neuron*, 2009)

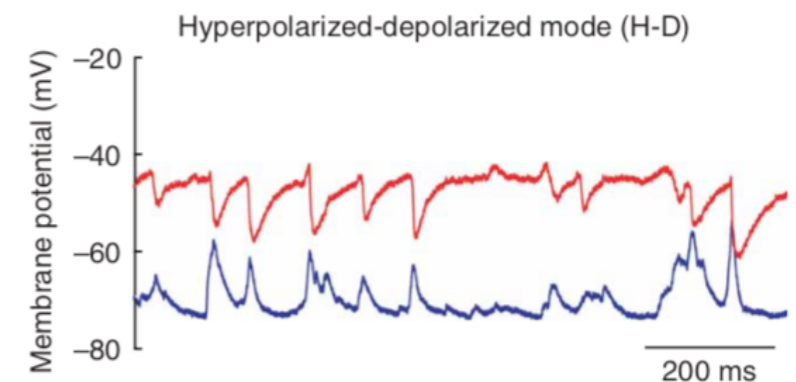

(Okun and Lampl, *Nature Neurosci.*, 2008)

# Balanced Network Models

$$\mathbf{r} \approx -W^{-1}\mathbf{X}$$

- **Problem 1:** Rates are a linear function of stimulus:

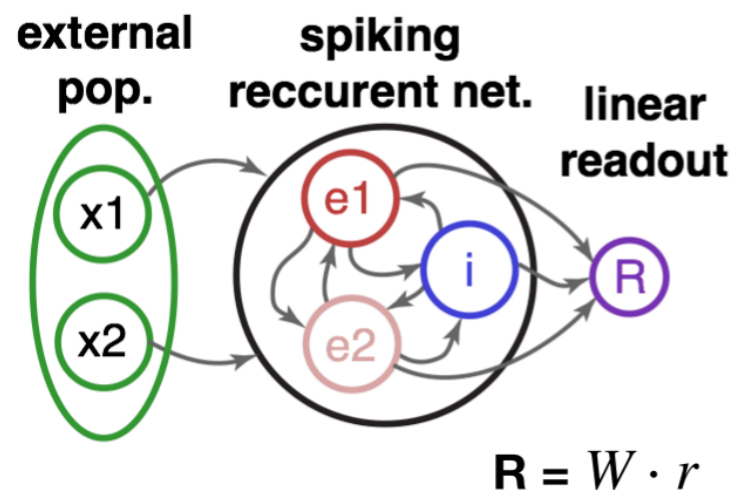

- **Problem 2:** Parameters must produce non-negative predicted rates:

$$-W^{-1}\mathbf{X} \geq 0$$

**Neuron manifold:** is an  $n_x - dim$  hyperplane in  $n - dim$  space

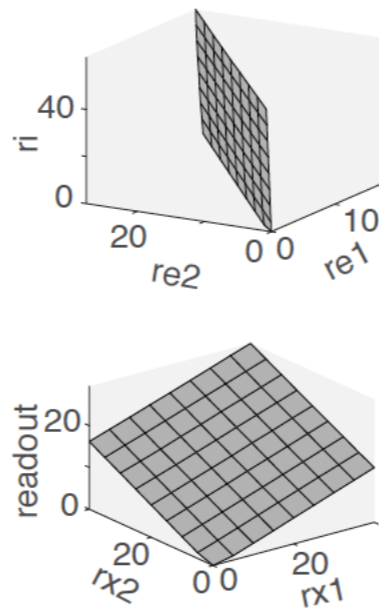

if  $n = |\{e_1, e_2 \dots i\}| \rightarrow \infty$ , then **hard** to find  $n_x = \{r_{x1}, r_{x2} \dots\}$  satisfying  $-w^{-1}X \geq 0$

**but cortex performs nonlinear computations!!!**

# My Work so far :

## Semi-balanced state

### Theorem:

for every  $W$  satisfies Dale's law, there exists an  $X > 0$  s.t.  $r = -W^{-1}X$  has negative entries.

- When balance is broken:  $[-W^{-1}X]_k < 0$ 
  - Excess inhibition to some populations, say  $e_1$
  - Remaining populations( $e_2$  &  $i$ ) form a balanced sub-network



**Semi-balanced state**

# Semi-balanced state

$$\mathbf{r} = [W\mathbf{r} + \mathbf{X} + \mathbf{r}]^+$$

- Non-linear mapping from stimulus to rates!
- More biologically realistic!

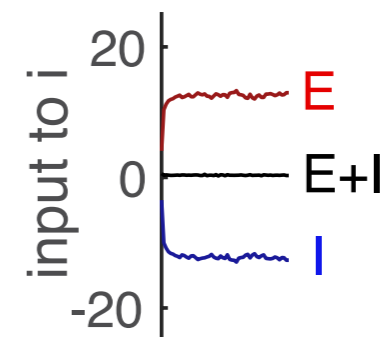
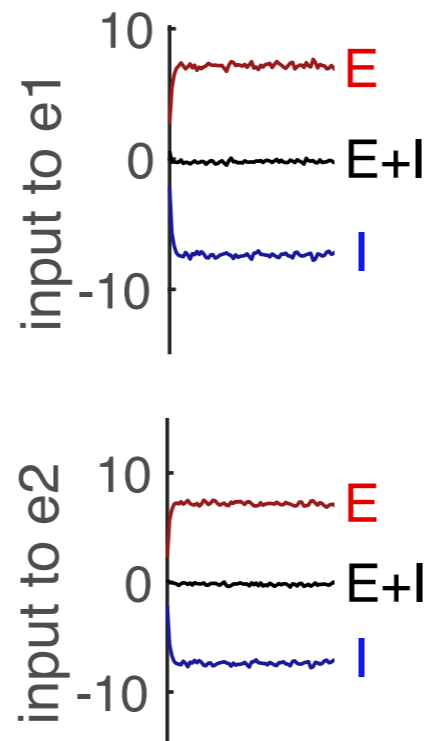
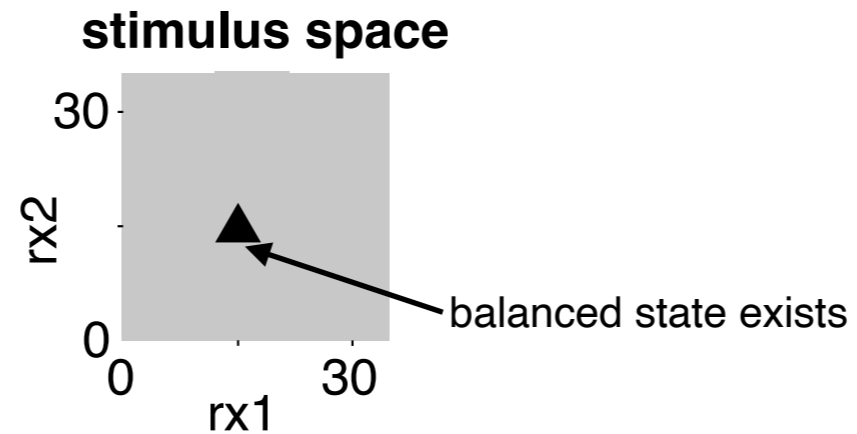
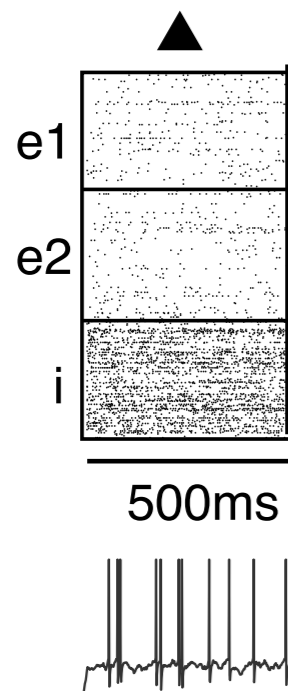
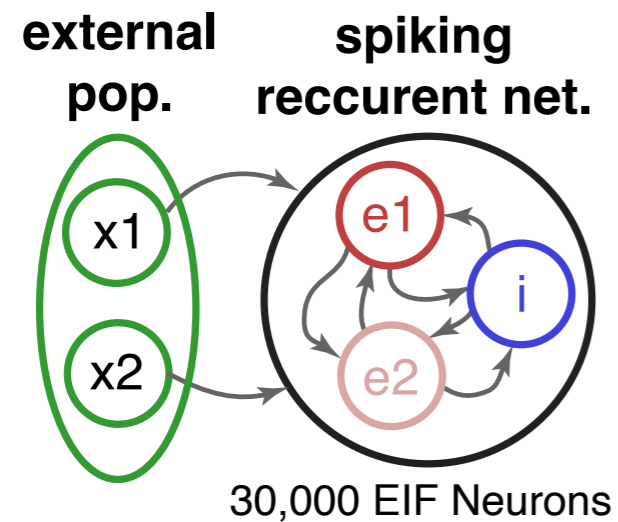



# Semi-balanced state

$$\mathbf{r} = [W\mathbf{r} + \mathbf{X} + \mathbf{r}]^+$$

- Non-linear mapping from stimulus to rates!
- More biologically realistic!

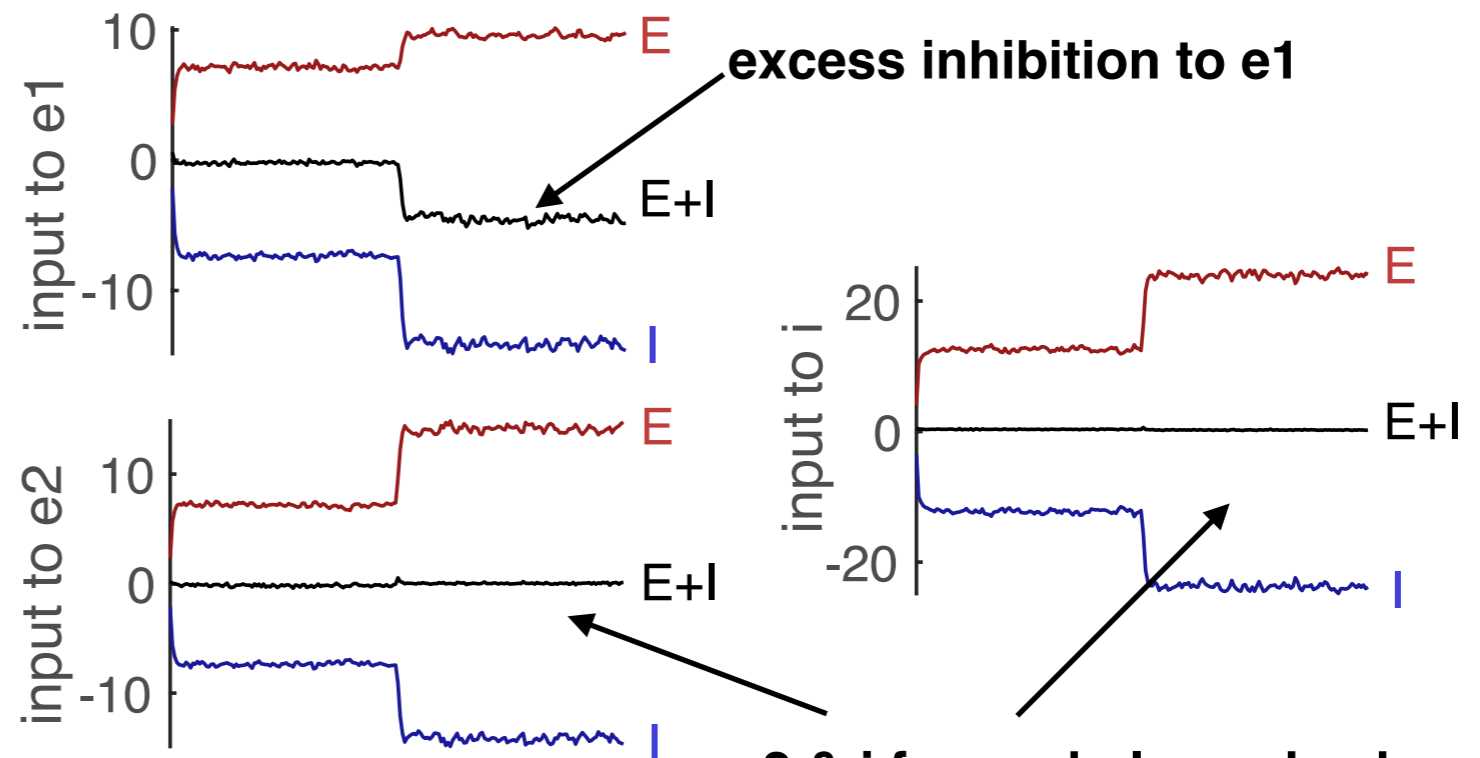
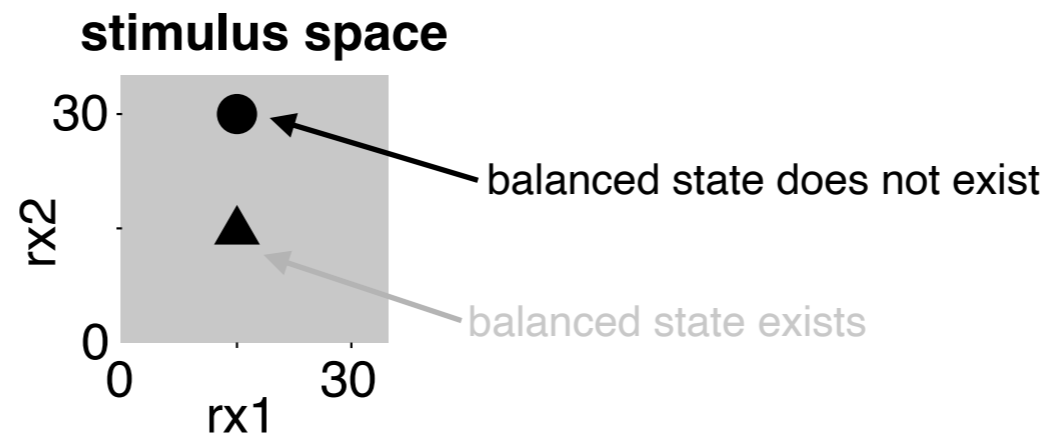
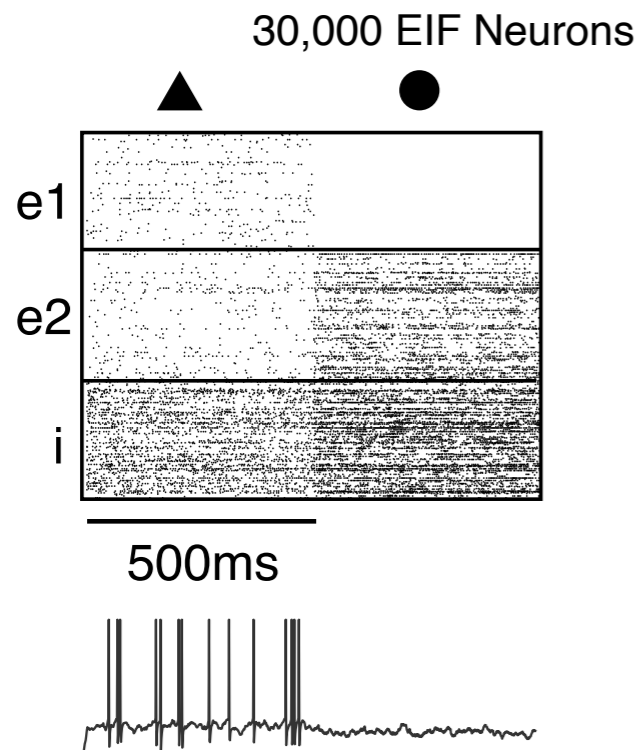
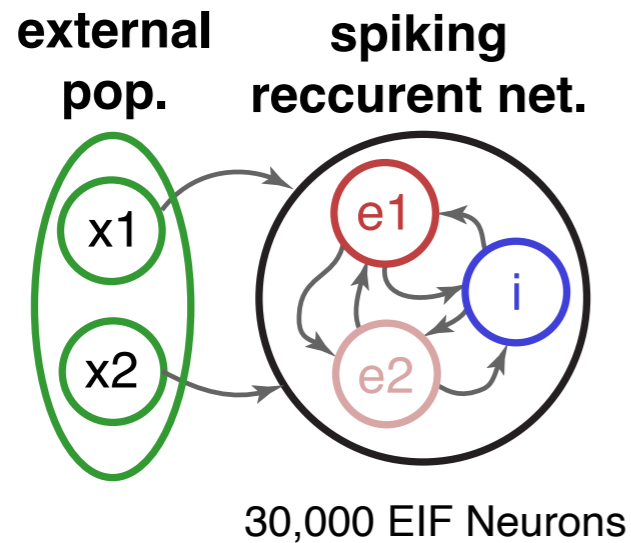

**e2 & i form a balanced sub-network**

# Semi-balanced states

$$\mathbf{r} = [W\mathbf{r} + \mathbf{X} + \mathbf{r}]^+$$

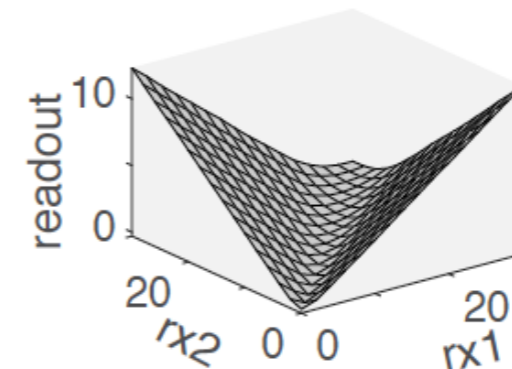
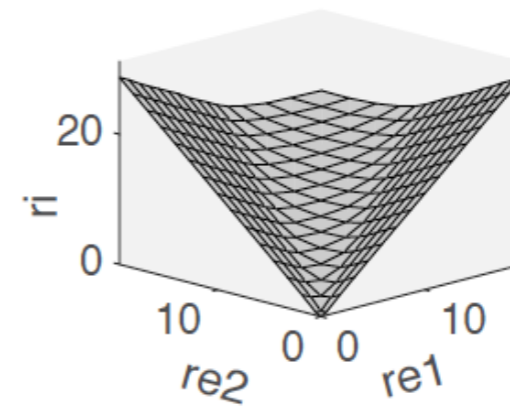
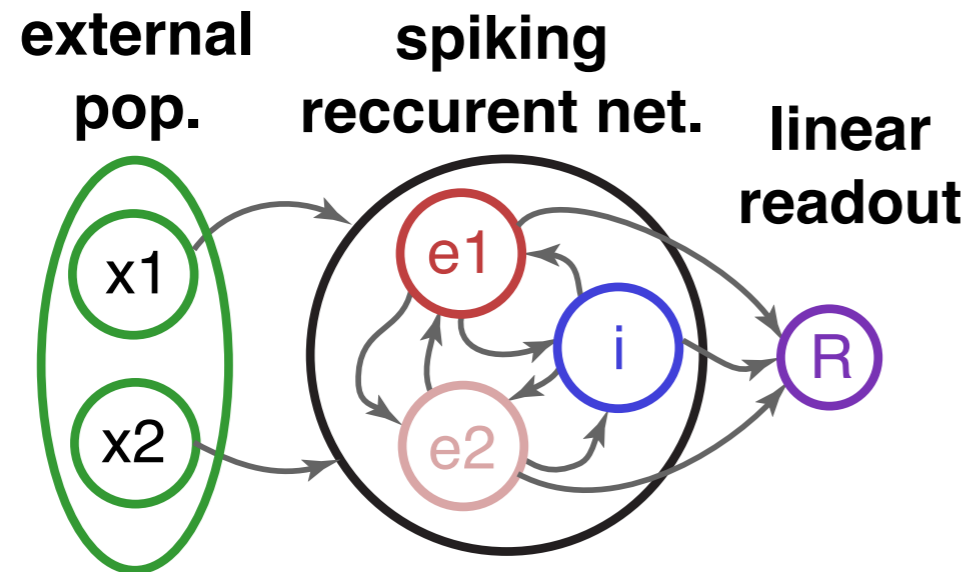

**It implements nonlinear stimulus representation !!!**

# Plasticity

**Plasticity:** the changes of synaptic weight,  $\Delta J_{jk}$ .

(i.e. Hebbian rule: “neurons fire together wire together”, )

**Spike-timing-depedent Plasticity(STDP):**  $\Delta J_{jk}$  is related to  $\Delta t = |t_j^n - t_k^n|$  with pre-syn neuron(k) and post-syn neuron(j) at n-th spike.

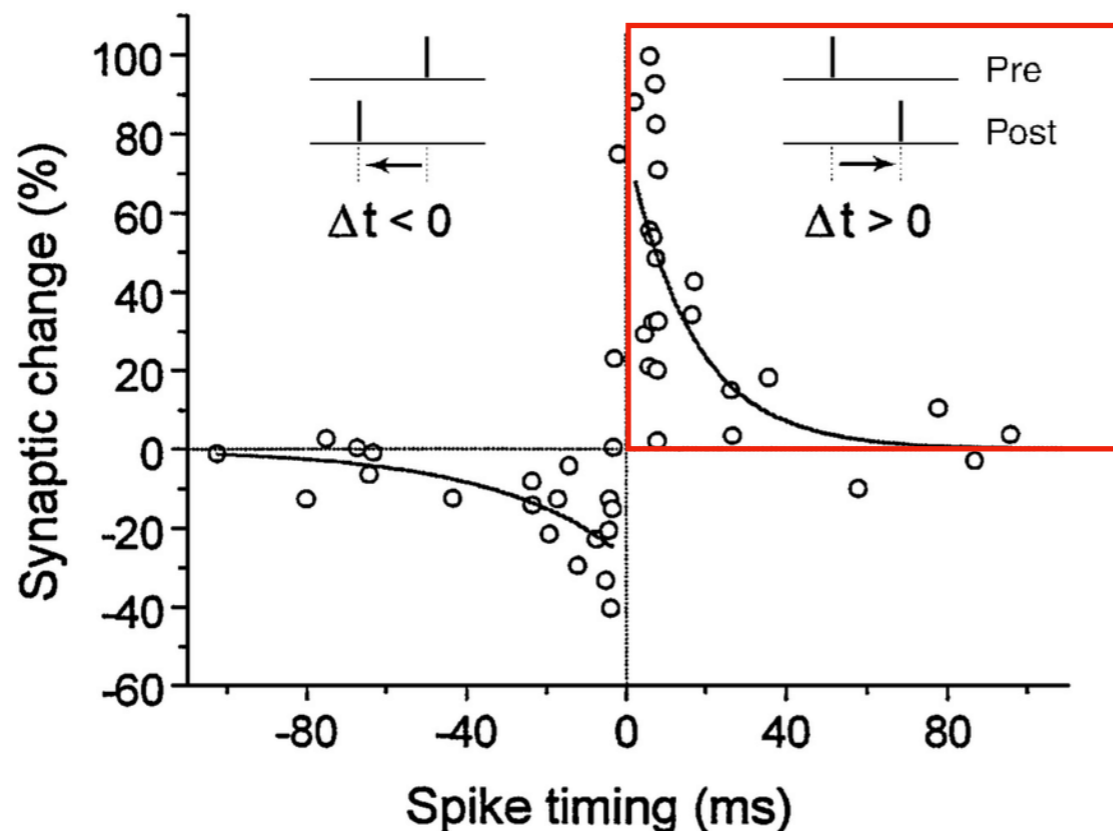

**Potentiation:**  $\Delta J_{jk} > 0$

**Depression:**  $\Delta J_{jk} < 0$

(Experiment, Bi & Poo, 1998)

## Our focus:

Implement the STDP rule in **inhibitory** synapses connections:  $\begin{cases} \Delta J^{ae} = 0 \\ \Delta J^{ai} \neq 0 \end{cases}$

# Plasticity

**Inhibitory Synaptic Plasticity (ISP):** it updates with learning ( $\eta_a$ ) and target rate ( $r_a^0$ ).

$$J_{jk}^{ai} \leftarrow J_{jk}^{ai} + \eta_a J_{jk}^{ai} (x_j^a - 2r_a^0) \quad \text{after each pre-syn spike at time } t_k^n$$

$$J_{jk}^{ak} \leftarrow J_{jk}^{ai} + \eta_a J_{jk}^{ai} (x_k^i) \quad \text{after post-syn spikes at time } t_j^n$$

**Synaptic trace:** to measure the running-average of the firing rate

over previous  $\tau_{STDP}$  window,  $x_j^a(t) \leftarrow x_j^a(t) + \frac{1}{\tau_{STDP}}$

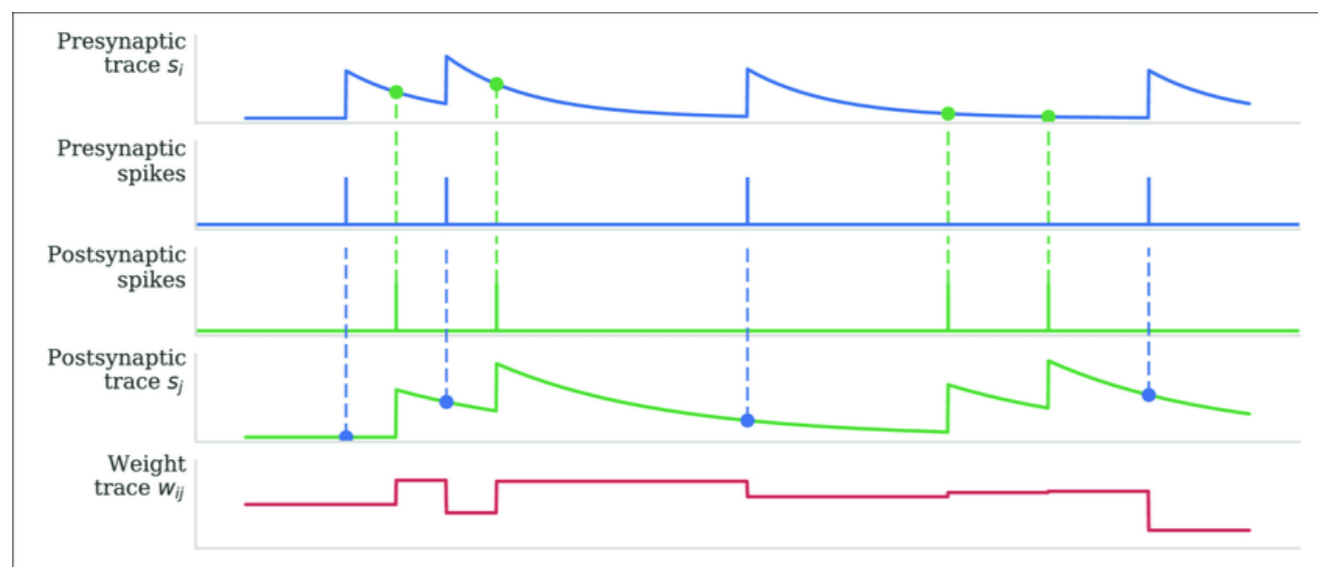

(Morrison et al. 2008)

# ISP in spiking EIF models

## Recurrent Network

### feedforward

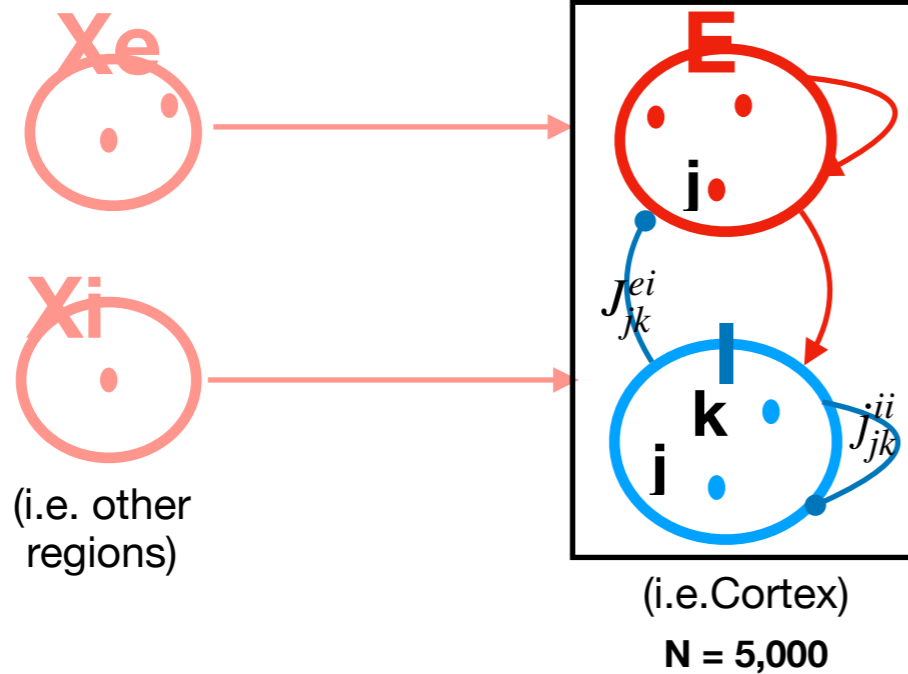

Time-avg. Current for 50 neurons

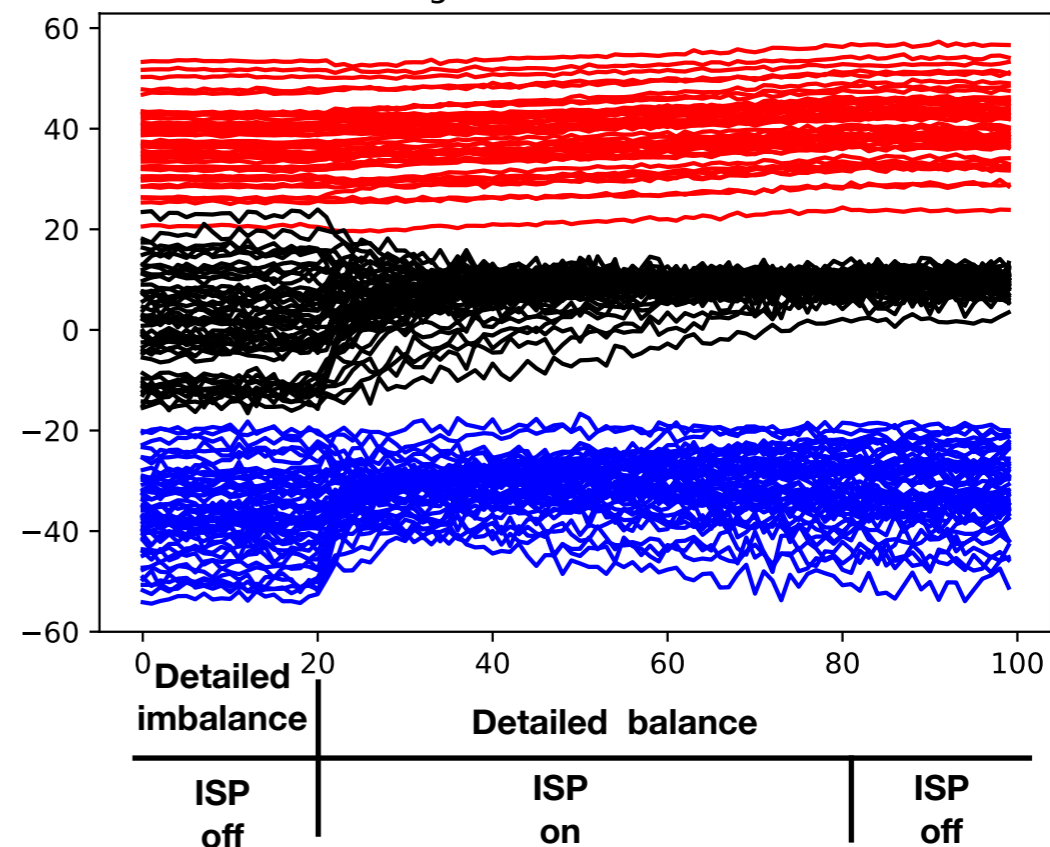

Time-avg. Firing rates for 50 exc. neurons

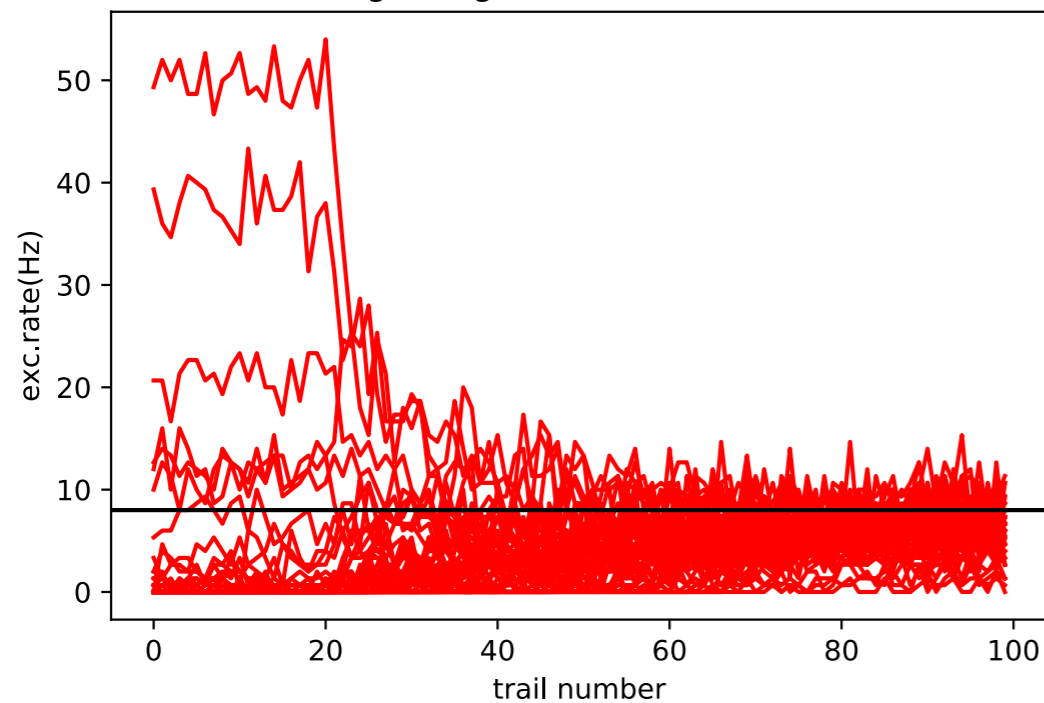

Time-avg. Firing rates for 50 inh. neurons

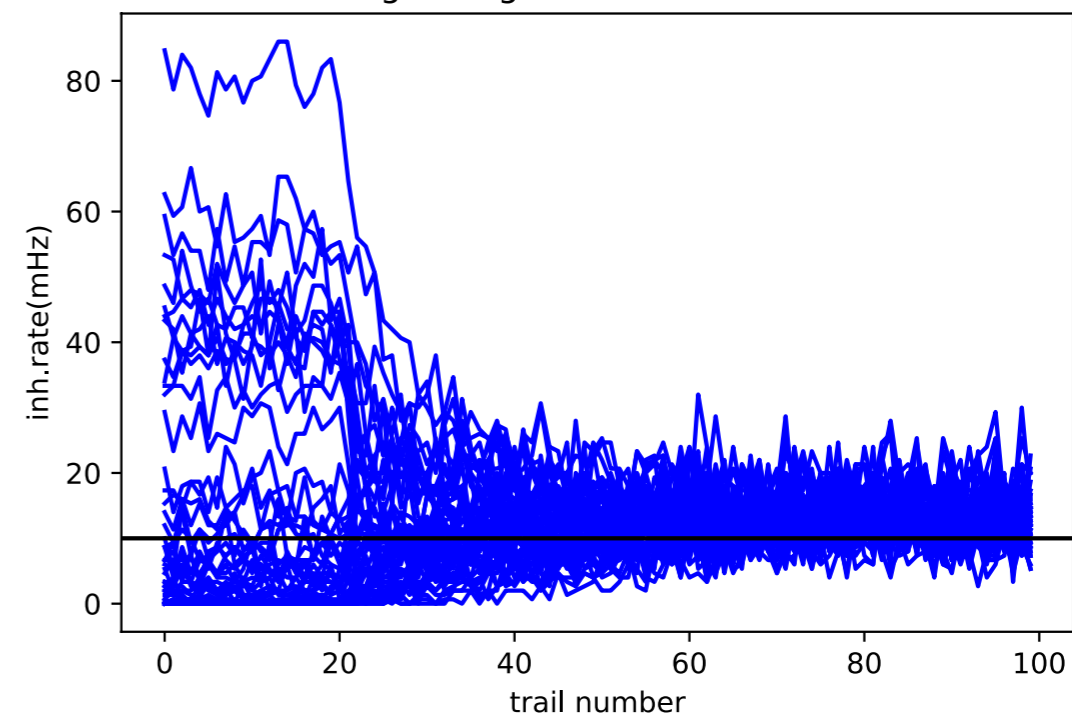

# Summary & Discussion :

## A brief history of neuronal models:

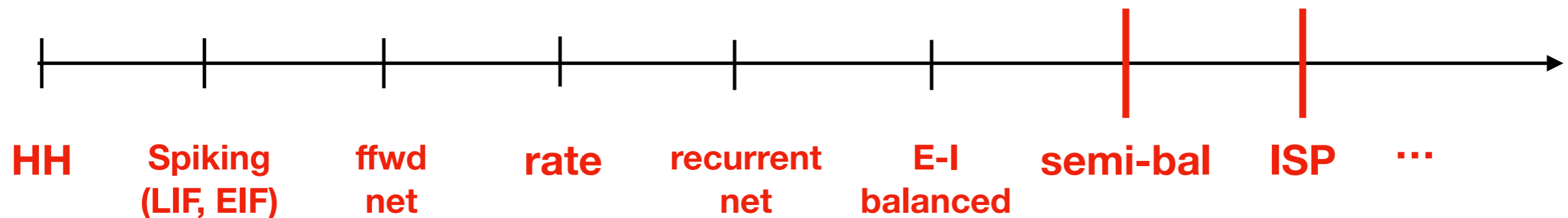

## Some difficulties that I encountered:

1. Computational cost: use GPU, CuPy lib.
2. Stability analysis of rate model: after dynamics course...
3. Parameter tuning: learning rate is too fast/slow!
4. ...

# In the future...

## 1. Understand ISP in rate models :

	Before	During	After
Task 1	X1, <b>X2</b> , X1, X2, ...	X1, X1, X1, X1...	X1, X2, X1, X2...
Task 2	X1, X2, X1, X2, ...	X1, X2, X1, X2...	X1, X2, <b>X3</b> , X1...
Task 3	X1+Y1, X2+Y2, ...	X1+Y1, X2+Y2, ...	Xi+Yi, <b>Xi+Y-i</b> , ...
...			

## 2. Connect to Artificial Neural Network & machine learning :

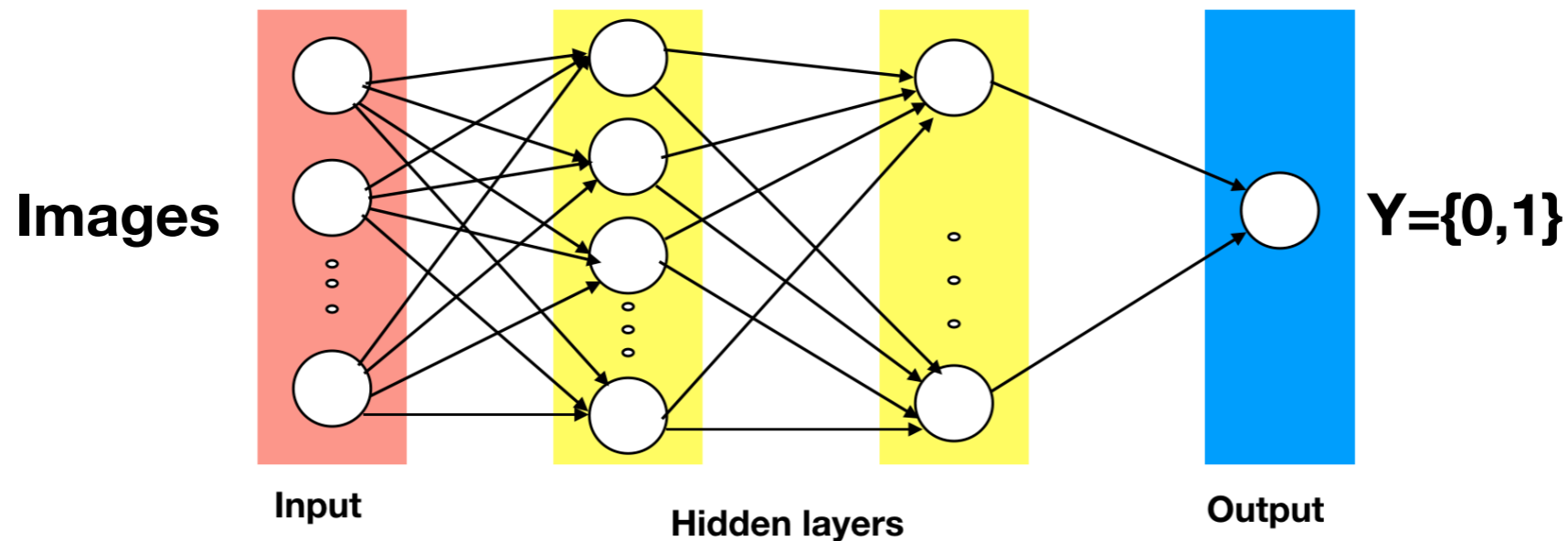

## 3. Apply Bayesian Models in brain dynamics: predictive coding

...

# References

[1] Cody Baker, Vicky Zhu, and Robert Rosenbaum. Nonlinear stimulus representations in neural circuits with approximate excitatory-inhibitory balance. bioRxiv.(2019).

[2] Ian Goodfellow, Joshua Bengio, and Aaron Courville. *Deep learning*. MIT Press.(2016).

[3] Peter Dayan and L.F. Abbott. *Theoretical Neuroscience: Computational and mathematical modelling of Neural Systems*.MIT Press. (2001).

[4] Vogels, T.P., Sprekeler, H., Zenke, F., Clopath, C., & Gerstner, W. Inhibitory plasticity balances excitation and inhibition in sensory pathways and memory networks. *Science* 334, 1569-73 (2011).

[5] Wulfram Gerstner, Werner M. Kistler, Richard Naud and Liam Paninski. *Neuronal Dynamics: From Single Neurons to Networks and Models of Cognition*. Cambridge University Press. (2014).



# Thank you!

All the code I use for plotting is available on my website:  
<https://vickcul.github.io/>

